



**CITY OF WESTFIELD, IN**  
**City Council Meeting Agenda**

---

**BOARD OR COMMISSION: City Council Meeting**

**MEETING DATE: Monday, February 9, 2026 at 7:00 PM**

**MEETING PLACE: Westfield City Hall- Assembly Room**

**THE FOLLOWING AGENDA IS SUBJECT TO CHANGE AT THE DISCRETION OF CITY COUNCIL**

Westfield City Council Members

Term 1/1/2024 -12-31-27

Jon Dartt, (District 1)

Victor McCarty, (District 2)

Joe Duepner, (District 3)

Patrick T. Tamm, (District 4)

Noah Herron, (District 5)

Chad Huff, (At Large)

Kurt Wanninger, (At Large)

**CALL TO ORDER**

Pledge of Allegiance

Invocation: Phil Hoard, Union Bible College

**OPENING OF MEETING**

Note the presence of a quorum

Approval of Minutes

Approval of Claims

Announce any changes to Agenda

**RESIDENTS WHO WISH TO ADDRESS COUNCIL**

**MISCELLANEOUS BUSINESS/SPECIAL RECOGNITION**

Special Recognition: Will Chambley

Swearing in of Westfield Firefighter

Presentation—Mayor's Youth Council

**OLD BUSINESS**

Ordinance 26-01: Amending the Provisions in the Westfield-Washington Township Unified Development Ordinance/Sign Standards

Staff Planner: Lauren Gillingham-Teague/Council Sponsor: Victor McCarty

First Reading: January 12, 2026

APC Public Hearing: January 14, 2026

APC Workshop: January 20, 2026  
APC Recommendation: February 2, 2026  
Adoption Consideration: February 9, 2026

**NEW BUSINESS**

Ordinance 26-04: Authorizing and Approving an Additional Appropriation from the Operating Balance of the Capital Projects Fund  
Presented by: Jenell Fairman  
First Reading and **Public Hearing**: February 9, 2026  
Adoption Consideration: February 23, 2026

Ordinance 26-05: Annexation/Preserve at Cool Creek Phase II  
Staff Planner: Ryan Collingwood/Council Sponsor:  
First Reading and **Public Hearing**: February 9, 2026  
Adoption Consideration: February 23, 2026

Ordinance 26-07: Amending Provisions in the Westfield-Washington Township Unified Development Ordinance  
Staff Planner: Ryan Collingwood/Council Sponsor: Victor McCarty  
First Reading: February 9, 2026  
APC Public Hearing: March 2, 2026  
APC Recommendation: March 2, 2026  
Adoption Consideration: March 9, 2026

**CITY COUNCIL COMMENTS**

**MAYOR COMMENTS**

**ADJOURNMENT**



## **CALL TO ORDER**

### **Pledge of Allegiance**

### **Invocation: Eric Lohe, Crossroads Church**

Pastor Lohe was unable to attend. Invocation was given by Clerk-Treasurer, Marla Ailor.

## **OPENING OF MEETING**

### **Note the presence of a quorum**

All councilors except for Councilor Dartt attended in person, who attended virtually. Mayor Willis, and Clerk-Treasurer Ailor, were present.

### **Approval of Minutes**

The motion to approve was made by: Councilor Wanninger

Seconded by: Councilor Wanninger

Vote: Yes-7; No-0. Motion carried.

### **Approval of Claims**

The motion to approve was made by: Councilor McCarty

Seconded by: Councilor Wanninger

Vote: Yes-7; No-0. Motion carried.

### **Announce any changes to Agenda**

It was noted for the record, that Councilor Wanninger would be joining Councilor McCarty on the APC.

The special recognition and the Mayor's Youth Council presentation will be postponed until the February 9th meeting.

## **RESIDENTS WHO WISH TO ADDRESS COUNCIL**

Bill Koss spoke about the role of government and requested that greed nor graft affect our community.

## **MISCELLANEOUS BUSINESS/SPECIAL RECOGNITION**

### **Special Recognition: Will Chambley**

### **Presentation: Mayor's Youth Council**

## **OLD BUSINESS**

### **Ordinance 25-81 Harmony PUD Amendment III (Mixed-Use District, Area B**

**Staff Planner: Lauren Gillingham-Teague/Council Sponsor: Patric Tamm**

**First Reading: November 24, 2025**

**APC Public Hearing: December 1, 2025**

**APC Workshop: Waived**

**APC Recommendation: January 14, 2026**

**Council Adoption: January 26, 2026**

Lauren Gillinham-Teague was online to present. This is an amendment to approximately 5 acres on the northwest side of 146th and Ditch Road in the Harmony mixed-use district. The amendment would allow a senior housing development for independent adults aged 62 and older to be constructed. The development would include 67 condo units, in-house amenities including a community garden, outdoor fireplace area, and a heated underground parking garage.

Jon Doboswicz answered questions from council regarding the neighborhood meeting.

The motion to approve was made by: Councilor McCarty  
Seconded by: Councilor Wanninger  
Vote: Yes-6; No-1 (C. Huff). Motion carried.

**Ordinance 25-82: Amendment to the Unified Development Ordinance (LPH/Community PUD District  
Presented by: Daine Crabtree/Council Sponsor: Joe Duepner**

**First Reading: November 24, 2025**

**APC Public Hearing: December 1, 2025**

**APC Workshop: Waived**

**APC Recommendation: January 14, 2026**

**Adoption Consideration: January 26, 2026**

Kevin Todd was online to present. This ordinance proposes a general business underlying PUD located at the NE corner of 196th and East Street, across from the future Community Hospital. Community Health owns the land which was annexed in October 2025. Community Health is looking to partner with Lifepoint Health to create an extension for a behavioral health facility, which would be taxable.

Addison Bradford, (in-person) along with Joe Caesar (who was virtual) spoke regarding questions that they had received about the facility. Community Hospital will maintain its own security for the campus, which includes the acute care hospital and the behavioral health facility. The security staff will consist of 15 officers, with 3 officers on duty per shift, costing \$2–3M per year, which will be absorbed by Community Health. The average length of stay of the patients is 7 to 10 days. Patients who need additional services would be transferred to a 60–90-day more permanent facility. Mr. Bradford reiterated that there are no development incentives being requested, the inpatient rehab facility would be fully taxable and not part of the pilot agreement made with the adjacent hospital. There are 8 inpatient facilities in Marion County. This would be the first in Hamilton County. The question was asked if Kokomo had a facility like this, to which Mr. Bradford replied he did not believe so, but the majority of the patients would be coming from Community Hospital Westfield. There was continued discussion. Mayor Willis stated the whole process with Lifepoint has been disappointing, and feels the council is in a difficult position, making a very important decision for the community without a lot of data.

The motion to approve was made by: Councilor Dartt  
Seconded by: Councilor McCarty  
Vote: Yes-3, No-4. (N. Herron, C. Huff, P. Tamm, K. Wanninger). Motion failed.

**Ordinance 26-02: WWS PUD Amendment I**

**Staff Planner: Ryan Collingwood/Council Sponsor: Victor McCarty**

**First Reading: January 12, 2026**

**APC Public Hearing: January 14, 2026**

**APC Recommendation: January 14, 2026**

**Adoption Consideration: January 26, 2026**

Ryan Collingwood presented virtually. This is an amendment to the Westfield Washington Schools PUD district located northeast of the intersection at SR32 and Centennial Rd. The amendment is requesting to modify the landscape plan, which would control the development. Additional real estate is being added to the PUD, as well as an update to the concept plan now that site work has progressed.

The motion to approve was made by: Councilor Wanninger  
Seconded by: Councilor Huff  
Vote: Yes-7; No-0. Motion carried.

**NEW BUSINESS**

**Ordinance 26-03: BUILT PUD**

**Staff Planner: Lauren Gillingham-Teague/Council Sponsor: Kurt Wanninger**

**First Reading: January 26, 2026**

**APC Public Hearing: February 2, 2026**

**APC Workshop: March 16, 2026**

**APC Recommendation: April 6, 2026**

**Adoption Consideration: April 13, 2026**

Lauren Gillingham-Teague virtually introduced the BUILT PUD proposed to be located on the southwest corner of SR32 and Gray Road and north of the Midland Trace Trail. The subject real estate is approximately 11 acres in size for both areas A and B. The ordinance proposes the development of makerspace business suites on the northwest half of the site, leaving the remainder for future trail-oriented commercial development. The PUD as proposed, requires area A to be developed in substantial conformity with the architectural elevations, site plan, and landscape plan in the PUD. Area B is required to come back to council review prior to any future development.

Lisa Claghorn of Church Chruch Hittle and Antrim gave a presentation overview of the commercial makerspace facility. The facility will be designed to support entrepreneurship, workforce training, and small-scale fabrication, with the intent of providing workspaces for small business owners. The BUILT team has worked with city staff to create buildings that reflect a contemporary character appropriate to the makerspace environment by using durable materials, appropriate building scale and compliant lighting and sign standards. Ms. Claghorn noted the comments received from council regarding permitted uses. Council overwhelmingly supports the project but feels the language pertaining to permitted uses needs tightening

### **CITY COUNCIL COMMENTS**

Councilor McCarty gave an APC update.

President Tamm thanked the clerk for making sure the citizens realize that the city never shuts down. The public safety and public works departments, specifically, work to ensure the streets are clear and citizens remain safe. He appreciates the long hours and hard work that they put in.

### **MAYOR COMMENTS**

- Mayor Willis congratulated the Public Works employees for the amazing job they did on the snow event.
- Mayor Willis commended the Public Safety team on facing the extra load of challenging runs during tough weather conditions.
- Discussion of HB1001
- Waste Management services will run tomorrow. Services will be running on a one-day delay.
- City Services will be open tomorrow

### **ADJOURNMENT**

Councilor McCarty made the motion to adjourn.  
Meeting Adjourned at: 7:54PM

---

Clerk-Treasurer

---

President or Vice President

These minutes are a summary of actions taken at the City of Westfield Council meetings. A full video archive of the meeting is available for viewing at: <https://www.youtube.com/cityofwestfieldin>

I hereby certify that each of the above listed vouchers and invoices, or bills attached there to, are true and correct and I have audited same in accordance with IC5-11-10-1.6.

February 09, 2026

\_\_\_\_\_

Fiscal Officer

ALLOWANCE OF ACCOUNTS PAYABLE VOUCHERS

CITY OF WESTFIELD

We have examined the Accounts Payable Vouchers listed on the foregoing Register of Accounts Payable Vouchers consisting of 33 pages and except for accounts payables not allowed as shown on the Register such account payables are hereby allowed in the total amount of \$0 and pending director approval such accounts payables are hereby allowed in the total amount of \$0.

Dated this 9 day of February, 2026

\_\_\_\_\_

\_\_\_\_\_

\_\_\_\_\_

Signatures of Governing Board

Approved by State Board of Accounts for the City of Westfield, 2013

**Purchase Invoice Register**

City of Westfield

Report Date Range: 01/22/26..02/04/26

2/4/2026 10:18 AM

Page 1 of 15

WESTFIELD\KGAGNON

Fund No.	Fund Name	Buy-From Vendor Name	Buy-From Vendor No.	Invoice No.	Date	G/L Acct.	G/L Account Name	Description	Amount	Check No.	Check Date
101	General										
		<b>Administration</b>									
		VEN011986 Bridge Builder Strategies		APP135210	1/28/2026	101001349	ADM-SERVICES	Leadership Coaching	28,465.57		
		VEN011786 Riverview Health Foundation		APP135214	1/28/2026	101001347	ADM-PROMOTIONS	2026 Women of Vision	1,250.00		
		VEN001537 Payroll		APP135246	1/27/2026	101001111	ADM-SALARY	sal	33,844.62	500001310	1/27/2026
		VEN001537 Payroll		APP135246	1/27/2026	101001120	ADM-FICA /MEDICARE	fica	2,005.94	500001310	1/27/2026
		VEN001537 Payroll		APP135246	1/27/2026	101001120	ADM-FICA /MEDICARE	med	469.13	500001310	1/27/2026
		VEN001537 Payroll		APP135246	1/27/2026	101001121	ADM-PERF	perf	4,805.93	500001310	1/27/2026
		VEN012663 Empower		APP135263	1/29/2026	101001125	ADM-401A MATCHING	401a Match	1,103.97	500001306	1/29/2026
		VEN011986 Bridge Builder Strategies		APP135337	2/3/2026	101001349	ADM-SERVICES	Leadership Coaching	28,465.57		
		VEN012320 Copeland Law LLC		APP135341	2/3/2026	101001330	ADM-	Jan services	425.00		
		VEN011650 ADVISA		APP135431	2/3/2026	101001349	ADM-SERVICES	Coaching	9,000.00		
		VEN012320 Copeland Law LLC		APP135432	2/3/2026	101001330	ADM-	Flat fee	255.00		
		VEN011840 C L Coonrod and Co		APP135433	2/3/2026	101001331	ADM-CONSULTING	Jan services	9,984.07		
		<b>Subtotal for Administration</b>							<b>120,074.80</b>		
		<b>Police</b>									
		VEN012812 Joseph Lee		APP135226	1/28/2026	101002347	POLICE-PROMOTIONS	Santa Appearance	400.00		
		VEN012813 Edward Poynter		APP135227	1/28/2026	101002334	POLICE-	Misc Cleaning Supplies	51.96		
		VEN001225 Law Enforcement Training Board		APP135239	1/28/2026	101002334	POLICE-	FIREARMS INSTRUCTOR	75.00		
		VEN001225 Law Enforcement Training Board		APP135240	1/28/2026	101002334	POLICE-	FIREARMS INSTRUCTOR	75.00		
		VEN011312 Veridus Group		APP135241	1/28/2026	101002349	POLICE-SERVICES	OWNERS REP SERVICES-	13,030.10		
		VEN001537 Payroll		APP135246	1/27/2026	101002111	POLICE-SALARY	sal	386,030.60	500001310	1/27/2026
		VEN001537 Payroll		APP135246	1/27/2026	101002120	POLICE-FICA/MEDICARE	fica	4,916.43	500001310	1/27/2026
		VEN001537 Payroll		APP135246	1/27/2026	101002120	POLICE-FICA/MEDICARE	med	5,395.68	500001310	1/27/2026
		VEN001537 Payroll		APP135246	1/27/2026	101002121	POLICE-PERF	perf77	69,687.93	500001310	1/27/2026
		VEN001537 Payroll		APP135246	1/27/2026	101002121	POLICE-PERF	perf	11,700.18	500001310	1/27/2026
		VEN012663 Empower		APP135260	1/29/2026	101002120	POLICE-FICA/MEDICARE	SS Opt	18,001.57	500001304	1/29/2026
		VEN012663 Empower		APP135262	1/29/2026	101002125	POLICE-401A MATCHING	13 percent	80,385.00	500001305	1/29/2026
		VEN012663 Empower		APP135263	1/29/2026	101002125	POLICE-401A MATCHING	401a Match	620.18	500001306	1/29/2026
		VEN012663 Empower		APP135310	2/2/2026	101002125	POLICE-401A MATCHING	Police Contributions	221,739.54	500001308	2/2/2026
		VEN012037 Legal and Liability Risk Mang Insti		APP135398	2/3/2026	101002334	POLICE-	Trump, Sargent and Stevens	495.00		
		VEN000963 Indiana Drug Enforcement Asso		APP135399	2/3/2026	101002334	POLICE-	Wylie and Stubbs Conference	850.00		
		VEN012263 Fishers Police Foundation Inc		APP135400	2/3/2026	101002350	POLICE-	1 Year Cellebrite License for	9,250.00		
		VEN000917 Humane Society for Hamilton		APP135407	2/3/2026	101002349	POLICE-SERVICES	Strays	303.79		

**Purchase Invoice Register**

City of Westfield

Report Date Range: 01/22/26..02/04/26

2/4/2026 10:18 AM

Page 2 of 15

WESTFIELD\KGAGNON

Fund No.	Fund Name	Buy-From Vendor Name	Invoice No.	Date	GL Acct.	GL Account Name	Description	Amount	Check No.	Check Date
101	General									
	<b>Police</b>									
		VEN001341 MES-Indiana	APP135484	2/4/2026	101002334	POLICE-	Training Ultra Plus Cuffs,	417.60		
		VEN001856 Sun Badge Co	APP135486	2/4/2026	101002229	POLICE-UNIFORMS	Retired Officer Badges	364.00		
		VEN010627 T-Mobile USA	APP135487	2/4/2026	101002349	POLICE-SERVICES	LEA Tracking	115.00		
		VEN000317 CALEA	APP135488	2/4/2026	101002350	POLICE-	Annual Continuation Fee	4,595.00		
		VEN012320 Copeland Law LLC	APP135489	2/4/2026	101002330	POLICE-LEGAL	Merit Commissioner Retainer	2,000.00		
		<b>Subtotal for Police</b>						<b>830,499.56</b>		
	<b>Economic and Community Development</b>									
		VEN010114 Rundell Ernstberger Assoc Inc	APP135212	1/27/2026	101003310	ECD-PLANNING	Comp Plan	9,200.00		
		VEN001537 Payroll	APP135246	1/27/2026	101003111	ECD-SALARY	sal	57,928.79	500001310	1/27/2026
		VEN001537 Payroll	APP135246	1/27/2026	101003120	ECD-FICA/MEDICARE	fica	3,504.17	500001310	1/27/2026
		VEN001537 Payroll	APP135246	1/27/2026	101003120	ECD-FICA/MEDICARE	med	819.52	500001310	1/27/2026
		VEN001537 Payroll	APP135246	1/27/2026	101003121	ECD-PERF	perf	8,225.88	500001310	1/27/2026
		VEN012663 Empower	APP135263	1/29/2026	101003125	ECD-401A MATCHING	401a Match	1,890.08	500001306	1/29/2026
		VEN012799 Kurt West Garner	APP135395	2/3/2026	101003310	ECD-PLANNING	Historical work on Villages	5,000.00		
		<b>Subtotal for Economic and Community Development</b>						<b>86,568.44</b>		
	<b>F and E</b>									
		VEN007012 Elwood Fire Equipment	APP135217	1/28/2026	101004343	F AND E-BUILDING MAINT	Sta 83 fire suppression pipe	193.86		
		VEN000301 Buckeye Power Sales Co	APP135218	1/28/2026	101004343	F AND E-BUILDING MAINT	Sta 83	225.00		
		VEN000301 Buckeye Power Sales Co	APP135218	1/28/2026	101004343	F AND E-BUILDING MAINT	Sta 82	215.00		
		VEN000301 Buckeye Power Sales Co	APP135218	1/28/2026	101004343	F AND E-BUILDING MAINT	Sta 81	150.00		
		VEN000301 Buckeye Power Sales Co	APP135218	1/28/2026	101004343	F AND E-BUILDING MAINT	PSB	235.00		
		VEN000301 Buckeye Power Sales Co	APP135218	1/28/2026	101004343	F AND E-BUILDING MAINT	GRPK	235.00		
		VEN000301 Buckeye Power Sales Co	APP135218	1/28/2026	101004343	F AND E-BUILDING MAINT	CSC	260.00		
		VEN007012 Elwood Fire Equipment	APP135221	1/28/2026	101004343	F AND E-BUILDING MAINT	Sta 82 back flow rebuild	965.94		
		VEN007012 Elwood Fire Equipment	APP135222	1/28/2026	101004343	F AND E-BUILDING MAINT	City Hall Fire suppression	715.98		
		VEN001537 Payroll	APP135246	1/27/2026	101004111	F AND E-SALARY	sal	28,539.22	500001310	1/27/2026
		VEN001537 Payroll	APP135246	1/27/2026	101004120	F AND E-FICA/MEDICARE	fica	1,678.02	500001310	1/27/2026
		VEN001537 Payroll	APP135246	1/27/2026	101004120	F AND E-FICA/MEDICARE	med	392.44	500001310	1/27/2026
		VEN001537 Payroll	APP135246	1/27/2026	101004121	F AND E-PERF	perf	4,052.56	500001310	1/27/2026
		VEN012663 Empower	APP135263	1/29/2026	101004125	F AND E-401A MATCHING	401a Match	928.25	500001306	1/29/2026
		VEN011079 Leimbach Electric	APP135282	1/30/2026	101004343	F AND E-BUILDING MAINT	Sta 81	2,400.00		

**Purchase Invoice Register**

City of Westfield

Report Date Range: 01/22/26..02/04/26

2/4/2026 10:18 AM

Page 3 of 15

WESTFIELD\KGAGNON

Fund No.	Fund Name	Buy-From Vendor Name	Invoice No.	Date	G/L Acct.	G/L Account Name	Description	Amount	Check No.	Check Date
101	General									
	<b>F and E</b>									
		VEN008187 Ace Party Rental	APP135283	1/30/2026	101004347	F AND E-PROMOTIONS	WR4 deposit	21,228.18		
		VEN000589 Duke Energy	APP135299	2/2/2026	101004341	F AND E-ELECTRIC	Sta 81	4,354.58	83328	2/2/2026
		VEN000589 Duke Energy	APP135300	2/2/2026	101004341	F AND E-ELECTRIC	City Hall	526.54	83329	2/2/2026
		VEN000589 Duke Energy	APP135300	2/2/2026	101004341	F AND E-ELECTRIC	Sta 83	1,179.39	83329	2/2/2026
		VEN000589 Duke Energy	APP135300	2/2/2026	101004341	F AND E-ELECTRIC	Sta 82	914.09	83329	2/2/2026
		VEN000589 Duke Energy	APP135302	2/2/2026	101004341	F AND E-ELECTRIC	CSC	537.90	83331	2/2/2026
		VEN002336 Citizens Westfield	APP135305	2/2/2026	101004342	F AND E-WATER/SEWER	Sta 82	297.63	83325	2/2/2026
		VEN010310 Premier Commercial Services	APP135329	2/3/2026	101004343	F AND E-BUILDING MAINT	CSC	3,060.13		
		VEN010310 Premier Commercial Services	APP135329	2/3/2026	101004343	F AND E-BUILDING MAINT	PSB	1,602.50		
		VEN010310 Premier Commercial Services	APP135329	2/3/2026	101004343	F AND E-BUILDING MAINT	PW	914.06		
		VEN010310 Premier Commercial Services	APP135329	2/3/2026	101004343	F AND E-BUILDING MAINT	City Hall	448.70		
		VEN010310 Premier Commercial Services	APP135329	2/3/2026	101004343	F AND E-BUILDING MAINT	Sta 81	217.94		
		VEN010310 Premier Commercial Services	APP135329	2/3/2026	101004343	F AND E-BUILDING MAINT	Camilla Ct	70.00		
		VEN012017 Culligan Ultrapurure Inc	APP135339	2/3/2026	101004343	F AND E-BUILDING MAINT	CSC	324.95		
		VEN012017 Culligan Ultrapurure Inc	APP135339	2/3/2026	101004343	F AND E-BUILDING MAINT	PSB	59.98		
		VEN012017 Culligan Ultrapurure Inc	APP135339	2/3/2026	101004343	F AND E-BUILDING MAINT	City Hall	35.00		
		VEN012035 Wiss Janney Elstner Assoc Inc	APP135348	2/3/2026	101004349	F AND E-SERVICES	Union Square parking garage	420.00		
		VEN001881 Taft Stettinius and Hollister	APP135349	2/3/2026	101004349	F AND E-SERVICES	Nov services	864.50		
		VEN001783 Shenwin-Williams	APP135393	2/3/2026	101004343	F AND E-BUILDING MAINT	Paint	1,215.00		
		VEN005717 BChex	APP135401	2/3/2026	101004349	F AND E-SERVICES	Background ck volunteers	216.75		
		VEN007391 Queen City Pyro Production	APP135490	2/4/2026	101004347	F AND E-PROMOTIONS	WR4	50,000.00		
		<b>Subtotal for F and E</b>						<b>129,674.09</b>		
	<b>Parks</b>									
		VEN001537 Payroll	APP135246	1/27/2026	101005111	PARKS-SALARY	sal	22,993.31	500001310	1/27/2026
		VEN001537 Payroll	APP135246	1/27/2026	101005120	PARKS-FICA/MEDICARE	fica	1,378.41	500001310	1/27/2026
		VEN001537 Payroll	APP135246	1/27/2026	101005120	PARKS-FICA/MEDICARE	med	322.37	500001310	1/27/2026
		VEN001537 Payroll	APP135246	1/27/2026	101005121	PARKS-PERF	perf	3,113.81	500001310	1/27/2026
		VEN012663 Empower	APP135263	1/29/2026	101005125	PARKS-401A MATCHING	401a Match	245.90	500001306	1/29/2026
		VEN000589 Duke Energy	APP135300	2/2/2026	101005341	PARKS-ELECTRIC	Parks	2,128.22	83329	2/2/2026
		VEN002336 Citizens Westfield	APP135306	2/2/2026	101005342	PARKS-WATER/SEWER	Parks	136.32	83326	2/2/2026
		VEN002336 Citizens Westfield	APP135307	2/2/2026	101005342	PARKS-WATER/SEWER	GRJN	348.21	83327	2/2/2026
		VEN000480 CSI Signs	APP135342	2/3/2026	101005228	PARKS-SIGNS AND POSTS	Adopt a Street signage	512.44		

**Purchase Invoice Register**

City of Westfield

Report Date Range: 01/22/26..02/04/26

2/4/2026 10:18 AM

Page 4 of 15

WESTFIELD\KGAGNON

Buy-From Vendor No.	Buy-From Vendor Name	Invoice No.	Date	G/L Acct.	G/L Account Name	Description	Amount	Check No.	Check Date
<b>Parks</b>									
VEN009542	H and N Outdoor Services LLC	APP135360	2/3/2026	101005349	PARKS-SERVICES	High Profile Maint	51,324.98		
VEN009542	H and N Outdoor Services LLC	APP135360	2/3/2026	101005349	PARKS-SERVICES	Low Profile Maint	19,637.00		
VEN009542	H and N Outdoor Services LLC	APP135360	2/3/2026	101005349	PARKS-SERVICES	PSB	1,765.00		
VEN009542	H and N Outdoor Services LLC	APP135360	2/3/2026	101005349	PARKS-SERVICES	3 Fire Stations	1,785.00		
VEN009542	H and N Outdoor Services LLC	APP135360	2/3/2026	101005349	PARKS-SERVICES	Library	2,457.50		
VEN009727	New Era Technology	APP135394	2/3/2026	101005343	PARKS-BUILDING	GRJN	825.00		
VEN000480	CSI Signs	APP135425	2/3/2026	101005228	PARKS-SIGNS AND POSTS	Trail DS T Stake	856.20		
VEN003729	Metronet	APP135426	2/3/2026	101005349	PARKS-SERVICES	GRJN	294.18	83335	2/3/2026
<b>Subtotal for Parks</b>							<b>110,123.85</b>		
<b>Economic Dev</b>									
VEN010114	Rundell Ernstberger Assoc Inc	APP135231	1/28/2026	101006349	ECONOMIC DEV-SERVICE	Jersey Prelim Design	24,112.00		
VEN001537	Payroll	APP135246	1/27/2026	101006111	ECONOMIC DEV-SALARY	sal	22,371.63	500001310	1/27/2026
VEN001537	Payroll	APP135246	1/27/2026	101006120	ECONOMIC DEV-	fica	1,331.83	500001310	1/27/2026
VEN001537	Payroll	APP135246	1/27/2026	101006120	ECONOMIC DEV-	med	311.48	500001310	1/27/2026
VEN001537	Payroll	APP135246	1/27/2026	101006121	ECONOMIC DEV-PERF	perf	3,176.77	500001310	1/27/2026
VEN012663	Empower	APP135263	1/29/2026	101006125	ECONOMIC DEV-401A	401a Match	545.00	500001306	1/29/2026
VEN012694	McCarter and English LLP	APP135491	2/4/2026	101006349	ECONOMIC DEV-SERVICE	Dec services Park St	3,480.00		
VEN012694	McCarter and English LLP	APP135492	2/4/2026	101006349	ECONOMIC DEV-SERVICE	Dec services Jersey St	8,047.50		
<b>Subtotal for Economic Dev</b>							<b>63,376.21</b>		
<b>Informatics</b>									
VEN011073	Resultant LLC	APP135219	1/28/2026	101007331	IT-CONSULTING	BI services	3,300.00		
VEN011073	Resultant LLC	APP135220	1/28/2026	101007331	IT-CONSULTING	BI services	3,410.00		
VEN005272	SHI International	APP135225	1/28/2026	101007389	IT-SOFTWARE LICENSING	Software	4,767.23		
VEN009100	C M Buck and Associates	APP135234	1/28/2026	101007349	IT-SERVICES	PS Data Center Critical UPS	5,700.00		
VEN002050	Verizon Wireless	APP135236	1/28/2026	101007332	IT-CELL PHONES	Air cards and Cell phones	6,610.12	83321	1/28/2026
VEN008285	EnvelopIQ LLC	APP135237	1/28/2026	101007451	IT-COMPUTER/EQUIP	COW Card Access Upgrade	10,540.55		
VEN008285	EnvelopIQ LLC	APP135238	1/28/2026	101007451	IT-COMPUTER/EQUIP	COW card access upgrade	16,104.95		
VEN001537	Payroll	APP135246	1/27/2026	101007111	IT-SALARY	sal	30,412.12	500001310	1/27/2026
VEN001537	Payroll	APP135246	1/27/2026	101007120	IT-FICA/MEDICARE	fica	1,791.22	500001310	1/27/2026
VEN001537	Payroll	APP135246	1/27/2026	101007120	IT-FICA/MEDICARE	med	418.91	500001310	1/27/2026
VEN001537	Payroll	APP135246	1/27/2026	101007121	IT-PERF	perf	4,318.53	500001310	1/27/2026
VEN012663	Empower	APP135263	1/29/2026	101007125	IT-401A MATCHING	401a Match	695.33	500001306	1/29/2026

**Purchase Invoice Register**

City of Westfield

Report Date Range: 01/22/26..02/04/26

2/4/2026 10:18 AM

Page 5 of 15

WESTFIELD\KGAGNON

Fund No.	Fund Name	Buy-From Vendor No.	Buy-From Vendor Name	Invoice No.	Date	G/L Acct.	G/L Account Name	Description	Amount	Check No.	Check Date
101	General										
	<b>Informatomics</b>										
		VEN003729	Metronet	APP135308	2/2/2026	101007349	IT-SERVICES	Denison	124.90	83332	2/2/2026
		VEN003729	Metronet	APP135331	2/3/2026	101007335	IT-TELEPHONE	CSC	888.77	83334	2/3/2026
		VEN012681	Haywire LLC	APP135338	2/3/2026	101007349	IT-SERVICES	Jan services	109.00		
		VEN005272	SHI International	APP135344	2/3/2026	101007389	IT-SOFTWARE LICENSING	Cradlepoint	536.92		
		VEN005272	SHI International	APP135345	2/3/2026	101007389	IT-SOFTWARE LICENSING	ESD Cradlepoint	2,051.59		
		VEN012446	MOSS	APP135346	2/3/2026	101007451	IT-COMPUTER/EQUIP	HPE Aruba	37,821.31		
		VEN009454	Cultivate Geospatial Solutions	APP135449	2/4/2026	101007331	IT-CONSULTING	Jan services	200.00		
		VEN006597	A TEC Inc	APP135450	2/4/2026	101007349	IT-SERVICES	Camera Maint 4th quart	6,255.00		
		VEN007202	TopoWorks	APP135451	2/4/2026	101007331	IT-CONSULTING	Jan services	2,915.00		
		VEN000604	Eastern Engineering Supply	APP135452	2/4/2026	101007337	IT-PRINTING	Instant Dry	524.98		
		VEN000617	elimage Technology Group	APP135453	2/4/2026	101007331	IT-CONSULTING	Jan services	8,700.00		
		VEN012548	Xerox IT Solutions LLC	APP135456	2/4/2026	101007331	IT-CONSULTING	NuWave	734.39		
		VEN011868	Sikich LLP	APP135457	2/4/2026	101007331	IT-CONSULTING	EDO	187.50		
		VEN012155	Safari Micro Inc	APP135458	2/4/2026	101007389	IT-SOFTWARE LICENSING	Jan Acrobat	161.88		
		VEN011780	Fairchild Communication Systems	APP135459	2/4/2026	101007451	IT-COMPUTER/EQUIP	Assembly room	4,228.08		
			<b>Subtotal for Informatomics</b>						<b>153,508.28</b>		
	<b>Clerk Treasurer</b>										
		VEN012671	Forvis Mazars LLP	APP135235	1/28/2026	101008331	CT-CONSULTING	Audit	45,000.00		
		VEN001537	Payroll	APP135246	1/27/2026	101008111	CT-SALARY	sal	21,552.65	500001310	1/27/2026
		VEN001537	Payroll	APP135246	1/27/2026	101008120	CT-FICA/MEDICARE	fica	1,295.48	500001310	1/27/2026
		VEN001537	Payroll	APP135246	1/27/2026	101008120	CT-FICA/MEDICARE	med	302.98	500001310	1/27/2026
		VEN001537	Payroll	APP135246	1/27/2026	101008121	CT-PERF	perf	2,607.38	500001310	1/27/2026
		VEN008854	Baker Tilly Municipal Advisors LLC	APP135258	1/29/2026	101008331	CT-CONSULTING	Services thru Jan	3,415.50		
		VEN008854	Baker Tilly Municipal Advisors LLC	APP135258	1/29/2026	101008331	CT-CONSULTING	Services thru Jan	8,172.72		
		VEN012663	Empower	APP135263	1/29/2026	101008125	CT-401A MATCHING	401a Match	716.70	500001306	1/29/2026
		VEN000837	Hamilton County Auditor Courthouse	APP135303	1/29/2026	101008338	CT-LEGAL NOTICES	ordinances	10.00	83323	1/29/2026
		VEN000847	Hamilton County Recorder	APP135304	1/29/2026	101008338	CT-LEGAL NOTICES	annex, ordinances	75.00	83324	1/29/2026
		VEN001826	Staples	APP135328	2/3/2026	101008223	CT-OFFICE SUPPLIES	Office Supplies	89.29		
		VEN001826	Staples	APP135343	2/3/2026	101008223	CT-OFFICE SUPPLIES	Office Supplies	190.53		
		VEN001195	Krieg Devault LLP	APP135352	2/3/2026	101008331	CT-CONSULTING	Dec services	1,233.00		
			<b>Subtotal for Clerk Treasurer</b>						<b>84,661.23</b>		

**Purchase Invoice Register**

City of Westfield

Report Date Range: 01/22/26..02/04/26

2/4/2026 10:18 AM

Page 6 of 15

WESTFIELD\KGAGNON

Buy-From Vendor No.	Buy-From Vendor Name	Invoice No.	Date	GL Acct.	GL Account Name	Description	Amount	Check No.	Check Date
<b>Fund No.</b>	<b>Fund Name</b>								
101	General								
	<b>Mayor</b>								
VEN001537	Payroll	APP135246	1/27/2026	101009111	MAYOR-SALARY	sal	5,097.39	500001310	1/27/2026
VEN001537	Payroll	APP135246	1/27/2026	101009120	MAYOR- FICA/MEDICARE	fica	294.46	500001310	1/27/2026
VEN001537	Payroll	APP135246	1/27/2026	101009120	MAYOR- FICA/MEDICARE	med	68.87	500001310	1/27/2026
VEN001537	Payroll	APP135246	1/27/2026	101009121	MAYOR-PERF	perf	723.83	500001310	1/27/2026
VEN012663	Empower	APP135263	1/29/2026	101009125	MAYOR-401A MATCHING	401a Match	204.00	500001306	1/29/2026
	<b>Subtotal for Mayor</b>						<b>6,388.55</b>		
	<b>Public Works</b>								
VEN000589	Duke Energy	APP135171	1/23/2026	101013341	PW-ELECTRIC	PW	200.77	83199	1/23/2026
VEN001537	Payroll	APP135246	1/27/2026	101013111	PW-SALARY	sal	81,881.00	500001310	1/27/2026
VEN001537	Payroll	APP135246	1/27/2026	101013120	PW-FICA/MEDICARE	fica	4,977.75	500001310	1/27/2026
VEN001537	Payroll	APP135246	1/27/2026	101013121	PW-PERF	perf	11,627.08	500001310	1/27/2026
VEN000589	Duke Energy	APP135300	2/2/2026	101013341	PW-ELECTRIC	Streets	803.96	83329	2/2/2026
VEN000589	Duke Energy	APP135301	2/2/2026	101013341	PW-ELECTRIC	PW	857.38	83330	2/2/2026
VEN010966	MKSK Inc	APP135330	2/3/2026	101013349	PW-CONTRACTUAL	SR 32 Streetscape Design	2,092.50		
VEN001676	Riverview Hospital	APP135335	2/3/2026	101013349	PW-CONTRACTUAL	Physical	99.00		
VEN000485	Current Publishing	APP135336	2/3/2026	101013349	PW-CONTRACTUAL	Notice Bids	22.34		
VEN000485	Current Publishing	APP135336	2/3/2026	101013349	PW-CONTRACTUAL	Notice Bids	101.34		
VEN000402	Cintas	APP135359	2/3/2026	101013229	PW-UNIFORMS	Uniforms	83.20		
VEN012166	Equipment Marketing Co	APP135387	2/3/2026	101013472	PW-EQUIPMENT	Patcher Vortex machine	115,825.00		
VEN000402	Cintas	APP135388	2/3/2026	101013229	PW-UNIFORMS	Boots	2,153.92		
VEN000402	Cintas	APP135391	2/3/2026	101013229	PW-UNIFORMS	Uniforms	85.80		
VEN010966	MKSK Inc	APP135428	2/3/2026	101013349	PW-CONTRACTUAL	SR 32 Streetscape Design	640.00		
VEN010966	MKSK Inc	APP135430	2/3/2026	101013349	PW-CONTRACTUAL	SR 32 Streetscape Design	232.50		
VEN010966	MKSK Inc	APP135438	2/3/2026	101013349	PW-CONTRACTUAL	SR 32 Streetscape Design	620.00		
VEN005717	BChex	APP135497	2/4/2026	101013349	PW-CONTRACTUAL	Background check	14.45		
	<b>Subtotal for Public Works</b>						<b>222,317.99</b>		
	<b>Communications</b>								
VEN011808	PIP Printing	APP135213	1/28/2026	101020347	COMM-PROMOTIONS	We Can Cards	53.53		
VEN012814	Justin Sicking Photography	APP135215	1/28/2026	101020347	COMM-PROMOTIONS	2026 Westfield Events	5,250.00		
VEN011808	PIP Printing	APP135223	1/28/2026	101020337	COMM-PRINTING	BSU Internship brochure	76.23		
VEN006678	Amazon Capital Services	APP135233	1/28/2026	101020347	COMM-PROMOTIONS	Badge holders	20.98		
VEN001537	Payroll	APP135246	1/27/2026	101020111	COMM-SALARY	sal	15,337.82	500001310	1/27/2026

**Purchase Invoice Register**

City of Westfield

Report Date Range: 01/22/26..02/04/26

2/4/2026 10:18 AM

Page 7 of 15

WESTFIELD\KGAGNON

Fund No.	Fund Name	Buy-From Vendor Name	Invoice No.	Date	GL Acct.	GL Account Name	Description	Amount	Check No.	Check Date
101	General									
	<b>Communications</b>									
	VEN001537	Payroll	APP135246	1/27/2026	101020120	COMM-FICA/MEDICARE	fica	912.38	500001310	1/27/2026
	VEN001537	Payroll	APP135246	1/27/2026	101020120	COMM-FICA/MEDICARE	med	213.38	500001310	1/27/2026
	VEN001537	Payroll	APP135246	1/27/2026	101020121	COMM-PERF	perf	2,177.98	500001310	1/27/2026
	VEN012663	Empower	APP135263	1/29/2026	101020125	COMM-401A MATCHING	401a Match	429.65	500001306	1/29/2026
	VEN011808	PIP Printing	APP135286	1/30/2026	101020337	COMM-PRINTING	Golf Cart Brochure	505.69		
	VEN000229	Beth Mair Photography	APP135287	1/30/2026	101020347	COMM-PROMOTIONS	Farm to Glass	125.00		
	VEN000485	Current Publishing	APP135347	2/3/2026	101020347	COMM-PROMOTIONS	Display ads	1,560.00		
	VEN000485	Current Publishing	APP135347	2/3/2026	101020347	COMM-PROMOTIONS	Digital ads	600.00		
		<b>Subtotal for Communications</b>						<b>27,262.64</b>		
	<b>Human Resources</b>									
	VEN012337	Standard Insurance Company	APP135136	1/22/2026	101022119	HR-HEALTH/DENTAL	Jan vision ins	3,417.59	83196	1/22/2026
	VEN000534	Delta Dental	APP135138	1/22/2026	101022119	HR-HEALTH/DENTAL	Jan dental ins	30,602.72	83195	1/22/2026
	VEN012269	Standard Insurance Company	APP135140	1/22/2026	101022119	HR-HEALTH/DENTAL	Jan Life ins	3,826.46	83197	1/22/2026
	VEN002177	Indiana Members Credit Union	APP135204	1/28/2026	101022119	HR-HEALTH/DENTAL		357,500.00	83320	1/28/2026
	VEN002177	Indiana Members Credit Union	APP135244	1/28/2026	101022119	HR-HEALTH/DENTAL	Employer HSA	349,000.00	83322	1/28/2026
	VEN001537	Payroll	APP135246	1/27/2026	101022111	HR-SALARY	sal	12,050.20	500001310	1/27/2026
	VEN001537	Payroll	APP135246	1/27/2026	101022120	HR-FICA/MEDICARE	fica	741.76	500001310	1/27/2026
	VEN001537	Payroll	APP135246	1/27/2026	101022120	HR-FICA/MEDICARE	med	173.48	500001310	1/27/2026
	VEN001537	Payroll	APP135246	1/27/2026	101022121	HR-PERF	perf	1,711.12	500001310	1/27/2026
	VEN012663	Empower	APP135263	1/29/2026	101022125	HR-401A MATCHING	401a Match	416.06	500001306	1/29/2026
	VEN011650	ADVISA	APP135495	2/4/2026	101022349	HR-SERVICE	Condensed DDM Quart	17,000.00		
	VEN007062	McGriff Insurance	APP135496	2/4/2026	101022339	HR-INSURANCE	Cyber Coverage Renewal	23,580.13		
	VEN005717	BChex	APP135497	2/4/2026	101022349	HR-SERVICE	Background check	26.40		
		<b>Subtotal for Human Resources</b>						<b>800,045.92</b>		
		<b>Subtotal for Fund 101 General</b>						<b>2,634,501.56</b>		
103	Fire Operating									
	<b>Fire</b>									
	VEN001537	Payroll	APP135246	1/27/2026	103012111	FIRE-SALARY	sal	683,141.84	500001310	1/27/2026
	VEN001537	Payroll	APP135246	1/27/2026	103012120	FIRE-FICA AND MEDICARE	fica	6,733.15	500001310	1/27/2026
	VEN001537	Payroll	APP135246	1/27/2026	103012120	FIRE-FICA AND MEDICARE	med	9,613.77	500001310	1/27/2026

**Purchase Invoice Register**

City of Westfield

Report Date Range: 01/22/26..02/04/26

2/4/2026 10:18 AM

Page 8 of 15

WESTFIELD\KGAGNON

Buy-From Vendor No.	Buy-From Vendor Name	Invoice No.	Date	G/L Acct.	G/L Account Name	Description	Amount	Check No.	Check Date
VEN001537	Payroll	APP135246	1/27/2026	103012121	FIRE-PERF	per77	111,096.70	500001310	1/27/2026
VEN001537	Payroll	APP135246	1/27/2026	103012121	FIRE-PERF	perf	15,667.97	500001310	1/27/2026
VEN012663	Empower	APP135260	1/29/2026	103012120	FIRE-FICA AND MEDICARE	SS Opt	29,871.62	500001304	1/29/2026
VEN012663	Empower	APP135262	1/29/2026	103012125	FIRE-401A MATCHING	13 percent	100,154.00	500001305	1/29/2026
VEN012663	Empower	APP135263	1/29/2026	103012125	FIRE-401A MATCHING	401a Match	83,089.50	500001306	1/29/2026
VEN000589	Duke Energy	APP135300	2/2/2026	103012346	FIRE-TORNADO SIREN	Sirens	73.01	83329	2/2/2026
VEN004836	Nationwide Retirement Solutions	APP135327	1/29/2026	103012124	FIRE-PEHP	PEHP	118,869.30	83333	2/3/2026
VEN006767	Knox Company	APP135460	2/4/2026	103012472	FIRE-EQUIP	knoxbbox	7,152.00		
VEN000073	Alert-all	APP135461	2/4/2026	103012244	FIRE-PREVENTION/PUBLIC	grab bags	900.00		
VEN000483	Cummins Crosspoint LLC	APP135462	2/4/2026	103012360	FIRE-VEHICLE MAINT	harness	1,717.39		
VEN007441	Conway Shields	APP135463	2/4/2026	103012229	FIRE-UNIFORMS	shields	218.50		
VEN004879	Penn Care Inc	APP135464	2/4/2026	103012360	FIRE-VEHICLE MAINT	valve solenoid	274.16		
VEN001783	Shenwin-Williams	APP135465	2/4/2026	103012224	FIRE-OPERATING	paint	47.08		
VEN001508	Palmer Power and Truck Equipment	APP135466	2/4/2026	103012360	FIRE-VEHICLE MAINT	repairs	12,863.40		
VEN000859	Hare Chevrolet	APP135467	2/4/2026	103012360	FIRE-VEHICLE MAINT	repairs to chevy 1500	835.88		
VEN007217	SimsUshare	APP135468	2/4/2026	103012350	FIRE-	yr subscription	495.00		
VEN001341	MES-Indiana	APP135469	2/4/2026	103012472	FIRE-EQUIP	bags/glass tool	1,139.88		
VEN012840	Hammerhead Industries	APP135470	2/4/2026	103012472	FIRE-EQUIP	core repl	217.98		
VEN007709	MacQueen Emergency Group	APP135471	2/4/2026	103012472	FIRE-EQUIP	new eng84	4,120.44		
VEN009277	Nelson and Co LLC	APP135472	2/4/2026	103012229	FIRE-UNIFORMS	shirts etc	1,377.36		
VEN000682	Fastenal	APP135473	2/4/2026	103012360	FIRE-VEHICLE MAINT	parts	40.05		
VEN000266	Bound Tree Medical	APP135474	2/4/2026	103012224	FIRE-OPERATING	ems supplies	2,965.01		
VEN011793	Keystone Cooperative Inc	APP135475	2/4/2026	103012226	FIRE-VEHICLE	fleet fuel	3,952.48		
VEN011988	Humana Health Plans	APP135476	2/4/2026	103012349	FIRE-SERVICES	ems reimburse	105.85		
VEN012157	UnitedHealthcare Community Plan	APP135477	2/4/2026	103012349	FIRE-SERVICES	ems reimburse	78.27		
VEN012841	Jeffrey S North	APP135478	2/4/2026	103012349	FIRE-SERVICES	ems reimburse	195.00		
VEN011839	Bravia Services LLC	APP135479	2/4/2026	103012349	FIRE-SERVICES	ems reimburse	8,400.00		
VEN008147	Move Over Outfitters Inc	APP135480	2/4/2026	103012472	FIRE-EQUIP	development	1,210.00		
VEN000065	Airgas Mid America	APP135481	2/4/2026	103012224	FIRE-OPERATING	edo308	2,447.29		
VEN011652	Nicholas Masterson	APP135482	2/4/2026	103012334	FIRE-	oxygen	98.00		
VEN000966	Indiana Fire Chiefs Assoc	APP135483	2/4/2026	103012350	FIRE-	reimbursement	1,075.00		
						IFCA			

**Purchase Invoice Register**

City of Westfield

Report Date Range: 01/22/26..02/04/26

2/4/2026 10:18 AM

Page 9 of 15

WESTFIELD\KGAGNON

Fund No.	Fund Name	Buy-From Vendor Name	Invoice No.	Date	G/L Acct.	G/L Account Name	Description	Amount	Check No.	Check Date
103	Fire Operating									
	Fire									
		VEN005717 BChex	APP135497	2/4/2026	103012349	FIRE-SERVICES	Background check	14.45		
		<b>Subtotal for Fire</b>						<b>1,210,251.33</b>		
		<b>Subtotal for Fund 103 Fire Operating</b>						<b>1,210,251.33</b>		
201	Motor Vehicle Highway (MVH)									
	Public Works									
		VEN001537 Payroll	APP135246	1/27/2026	201013111	MVH-SALARY	sal	13,897.99	500001310	1/27/2026
		VEN001537 Payroll	APP135246	1/27/2026	201013120	MVH-FICA/MEDICARE	fica	819.90	500001310	1/27/2026
		VEN001537 Payroll	APP135246	1/27/2026	201013120	MVH-FICA/MEDICARE	med	191.75	500001310	1/27/2026
		VEN001537 Payroll	APP135246	1/27/2026	201013120	MVH-FICA/MEDICARE	med	1,164.15	500001310	1/27/2026
		VEN001537 Payroll	APP135246	1/27/2026	201013121	MVH-PERF	perf	1,973.50	500001310	1/27/2026
		VEN012663 Empower	APP135263	1/29/2026	201013125	MVH-401A MATCHING	401a Match	154.14	500001306	1/29/2026
		VEN012663 Empower	APP135263	1/29/2026	201013125	MVH-401A MATCHING	401a Match	1,359.53	500001306	1/29/2026
		VEN000332 Cargill	APP135332	2/3/2026	201013231	MVH-SUBGRADE	Salt	8,355.06		
		VEN000879 Heritage-Crystal Clean	APP135334	2/3/2026	201013349	MVH-CONTRACTUAL SERV	Truck stop fee	150.00		
		VEN000332 Cargill	APP135340	2/3/2026	201013231	MVH-SUBGRADE	Salt	10,741.16		
		VEN000332 Cargill	APP135350	2/3/2026	201013226	MVH-VEHICLE GAS/	Salt	10,971.73		
		VEN011793 Keystone Cooperative Inc	APP135351	2/3/2026	201013226	MVH-VEHICLE GAS/	Fuel	1,115.44		
		VEN001363 Mid-state Truck Equipment	APP135353	2/3/2026	201013345	MVH-EQUIP REPAIR	Snow Plow parts	955.28		
		VEN009426 Best One of Tipton	APP135354	2/3/2026	201013345	MVH-EQUIP REPAIR	Tire repair 1991	482.75		
		VEN009426 Best One of Tipton	APP135354	2/3/2026	201013345	MVH-EQUIP REPAIR	Tire repair 1991	582.75		
		VEN006436 Davis Wholesale Supply	APP135356	2/3/2026	201013231	MVH-SUBGRADE	Brine Salt	5,036.65		
		VEN006436 Davis Wholesale Supply	APP135356	2/3/2026	201013231	MVH-SUBGRADE	Brine Salt	4,807.05		
		VEN012778 Poms Tire Service	APP135357	2/3/2026	201013345	MVH-EQUIP REPAIR	Dump Truck repair	1,160.13		
		VEN009542 H and N Outdoor Services LLC	APP135386	2/3/2026	201013349	MVH-CONTRACTUAL SERV	Snow Removal	160,310.00		
		VEN000332 Cargill	APP135389	2/3/2026	201013231	MVH-SUBGRADE	Salt	11,483.27		
		VEN000859 Hare Chevrolet	APP135392	2/3/2026	201013345	MVH-EQUIP REPAIR	Small Sweeper Repair	1,791.44		
		VEN000332 Cargill	APP135396	2/3/2026	201013231	MVH-SUBGRADE	Salt	4,657.43		
		VEN000332 Cargill	APP135396	2/3/2026	201013231	MVH-SUBGRADE	Salt	10,261.79		

**Purchase Invoice Register**

City of Westfield

Report Date Range: 01/22/26..02/04/26

2/4/2026 10:18 AM

Page 10 of 15

WESTFIELD\KGAGNON

Fund No.	Fund Name	Buy-From Vendor Name	Invoice No.	Date	G/L Acct.	G/L Account Name	Description	Amount	Check No.	Check Date
<b>201</b>	<b>Motor Vehicle Highway (MVH)</b>									
	<b>Public Works</b>									
	VEN000332	Cargill	APP135397	2/3/2026	201013231	MVH-SUBGRADE	Salt	14,283.29		
	VEN000332	Cargill	APP135403	2/3/2026	201013231	MVH-SUBGRADE	Salt	30,047.56		
	VEN001846	Stoops Freightliner	APP135445	2/4/2026	201013345	MVH-EQUIP REPAIR	Repair parts 2292	977.79		
	VEN001363	Mid-state Truck Equipment	APP135446	2/4/2026	201013345	MVH-EQUIP REPAIR	Cuttingedge	835.20		
	VEN000166	Auto Outfitters	APP135447	2/4/2026	201013345	MVH-EQUIP REPAIR	Wire Harness for snow plow	724.00		
	VEN003382	McGavic Outdoor Power	APP135448	2/4/2026	201013345	MVH-EQUIP REPAIR	Brine system	232.00		
	<b>Subtotal for Public Works</b>							<b>299,522.73</b>		
	<b>Subtotal for Fund 201 Motor Vehicle Highway (MVH)</b>							<b>299,522.73</b>		
<b>202</b>	<b>Local Road and Street (LRS)</b>									
	<b>Public Works</b>									
	VEN000921	Huston Electric	APP135358	2/3/2026	202013349	LRS-SERVICES	186th and Spring Mill	2,194.20		
	VEN001829	Stello Products Inc	APP135455	2/4/2026	202013228	LRS-SIGNS AND POSTS	Signs	1,719.70		
	<b>Subtotal for Public Works</b>							<b>3,913.90</b>		
	<b>Subtotal for Fund 202 Local Road and Street (LRS)</b>							<b>3,913.90</b>		
<b>204</b>	<b>Park Impact</b>									
	<b>Parks</b>									
	VEN010114	Rundell Ernberger Assoc Inc	APP135232	1/28/2026	204005349	PARK IMPACT-SERVICES	Park St Project	28,897.80		
	<b>Subtotal for Parks</b>							<b>28,897.80</b>		
	<b>Subtotal for Fund 204 Park Impact</b>							<b>28,897.80</b>		
<b>206</b>	<b>Parks Programming/Events</b>									
	<b>Parks</b>									
	VEN011253	Wander Marketing	APP135402	2/3/2026	206005347	PARKS PROGRAM-	Winter Market	600.00		
	<b>Subtotal for Parks</b>							<b>600.00</b>		
	<b>Subtotal for Fund 206 Parks Programming/Events</b>							<b>600.00</b>		

**Purchase Invoice Register**

City of Westfield

Report Date Range: 01/22/26..02/04/26

2/4/2026 10:18 AM

Page 11 of 15

WESTFIELD\KGAGNON

Fund No.	Fund Name	Buy-From Vendor Name	Invoice No.	Date	G/L Acct.	G/L Account Name	Description	Amount	Check No.	Check Date
255	F and E Programming/Events									
	F and E									
		VEN010560 Elle Sophia Pet Photography	APP135230	1/28/2026	2550004347	F AND E-EVENT PROG	Barktoberfest deposit	825.00		
	Subtotal for F and E							825.00		
	Subtotal for Fund 255 F and E Programming/Events							825.00		
262	Parks Rental									
	Parks									
		VEN012811 Sunbolt	APP135390	2/3/2026	262005472	PARKS RENTAL-	Deposit Solar picnic table	11,773.50		
	Subtotal for Parks							11,773.50		
	Subtotal for Fund 262 Parks Rental							11,773.50		
264	Road and Street Improvement (Road Impact)									
	Public Works									
		VEN005660 Morphe Construction	APP135229	1/28/2026	264013474	ROAD IMPACT-	161st St & Spring Mill Road	148,294.16		
		VEN007716 United Rentals	APP135355	2/3/2026	264013474	ROAD IMPACT-	Fencing around green bldg	792.00		
		VEN001364 Midwest Paving LLC	APP135404	2/3/2026	264013474	ROAD IMPACT-	Old 146th St & Towne Road	192,275.31		
	Subtotal for Public Works							341,361.47		
	Subtotal for Fund 264 Road and Street Improvement (Road Impact)							341,361.47		
266	Capital Projects									
	Informatics									
		VEN012423 BerryComm	APP135454	2/4/2026	266007474	CAPITAL PROJECT-	BOT installment	500,000.00		
	Subtotal for Informatics							500,000.00		
	Subtotal for Fund 266 Capital Projects							500,000.00		
269	Training Facility Center									
	Public Safety (Police and Fire)									
		VEN000589 Duke Energy	APP135300	2/2/2026	269014341	TRAINING FAC-ELECTRIC	Training Facility	197.29	83329	2/2/2026
	Subtotal for Public Safety (Police and Fire)							197.29		
	Subtotal for Fund 269 Training Facility Center							197.29		

**Purchase Invoice Register**

City of Westfield

Report Date Range: 01/22/26..02/04/26

2/4/2026 10:18 AM

Page 12 of 15

WESTFIELD\KGAGNON

Fund No.	Fund Name	Buy-From Vendor Name	Invoice No.	Date	G/L Acct.	G/L Account Name	Description	Amount	Check No.	Check Date
<b>305</b>	<b>Grand Junction TIF</b>									
	<b>RDC</b>									
	VEN009613	IMI Aggregates LLC	APP135224	1/28/2026	305018474	GRAND JUNCT TIF-	Park St Demo	3,048.26		
	VEN009613	IMI Aggregates LLC	APP135224	1/28/2026	305018474	GRAND JUNCT TIF-	Park St Demo	2,221.10		
	<b>Subtotal for RDC</b>							<b>5,269.36</b>		
	<b>Subtotal for Fund 305 Grand Junction TIF</b>							<b>5,269.36</b>		
<b>310</b>	<b>SEP TIF</b>									
	<b>RDC</b>									
	VEN012714	Argent Institutional Trust	APP135259	1/29/2026	310018131	SEP TIF-TSF	2020 Bond SEP project	117,467.21	500001303	1/29/2026
	<b>Subtotal for RDC</b>							<b>117,467.21</b>		
	<b>Subtotal for Fund 310 SEP TIF</b>							<b>117,467.21</b>		
<b>427</b>	<b>Cum. Capital Development</b>									
	<b>Police</b>									
	VEN006333	Axon Enterprise Inc	APP135216	1/28/2026	427002472	CCD-PD EQUIPMENT	AXON TASER 10-	726.12		
	VEN006333	Axon Enterprise Inc	APP135228	1/28/2026	427002472	CCD-PD EQUIPMENT	AXON BUNDLE OFFICER	467,190.97		
	VEN000569	Don Hinds Ford Inc	APP135485	2/4/2026	427002472	CCD-PD EQUIPMENT	2020 Chevy Tahoe Silver	35,549.25		
	<b>Subtotal for Police</b>							<b>503,466.34</b>		
	<b>Fire</b>									
	VEN011571	StudioAxis	APP135333	2/3/2026	427012474	CCD-FD CONSTR COST	Construction of Fire Stations	7,522.64		
	VEN011571	StudioAxis	APP135429	2/3/2026	427012474	CCD-FD CONSTR COST	Construction of Fire Stations	6,600.00		
	<b>Subtotal for Fire</b>							<b>14,122.64</b>		
	<b>Subtotal for Fund 427 Cum. Capital Development</b>							<b>517,588.98</b>		
<b>640</b>	<b>Sports Campus Operating</b>									
	<b>Sport Campus Indoor Event Ctr</b>									
	VEN008285	EnvelopIQ,LLC	APP135211	1/27/2026	640023451	GP INDOOR-COMPUTER	GP Access Control Project	1,285.00		
	<b>Subtotal for Sport Campus Indoor Event Ctr</b>							<b>1,285.00</b>		
	<b>Subtotal for Fund 640 Sports Campus Operating</b>							<b>1,285.00</b>		

**Purchase Invoice Register**

City of Westfield

Report Date Range: 01/22/26..02/04/26

2/4/2026 10:18 AM

Page 13 of 15

WESTFIELD\KGAGNON

Fund No.	Fund Name	Buy-From Vendor Name	Invoice No.	Date	G/L Acct.	G/L Account Name	Description	Amount	Check No.	Check Date
701	Payroll									
		<b>Clerk Treasurer</b>								
VEN002177	Indiana Members Credit Union	Indiana Members Credit Union	APP135131	1/22/2026	701008930	PAYROLL-INS. DED	HSA	221.15	19006	1/22/2026
VEN002177	Indiana Members Credit Union	Indiana Members Credit Union	APP135132	1/22/2026	701008930	PAYROLL-INS. DED	HSA	50.00	19007	1/22/2026
VEN002689	Brandon Taylor	Brandon Taylor	APP135133	1/22/2026	701008110	PAYROLL-NET SALARIES	Retro pay	929.50	19005	1/22/2026
VEN012337	Standard Insurance Company	Standard Insurance Company	APP135135	1/22/2026	701008930	PAYROLL-INS. DED	Jan vision retirees	67.81	19009	1/22/2026
VEN000534	Delta Dental	Delta Dental	APP135137	1/22/2026	701008930	PAYROLL-INS. DED	Jan dental ins retirees	521.59	19008	1/22/2026
VEN012269	Standard Insurance Company	Standard Insurance Company	APP135139	1/22/2026	701008930	PAYROLL-INS. DED	Jan Life ins	2,598.12	19010	1/22/2026
VEN001736	Sam Peterson	Sam Peterson	APP135141	1/22/2026	701008110	PAYROLL-NET SALARIES	Pay	165.00	19011	1/22/2026
VEN000058	AFLAC	AFLAC	APP135170	1/23/2026	701008930	PAYROLL-INS. DED	Dec ins	6,342.28	19012	1/23/2026
VEN001390	MISDU	MISDU	APP135205	1/28/2026	701008140	PAYROLL-SUPPORT	Child Support	289.89	19013	1/28/2026
VEN004836	Nationwide Retirement Solutions	Nationwide Retirement Solutions	APP135206	1/28/2026	701008931	PAYROLL-401A MATCHING-	Loan	69.68	19014	1/28/2026
VEN000948	IN Family and Social Services	IN Family and Social Services	APP135207	1/28/2026	701008140	PAYROLL-SUPPORT	Child Support	2,256.00	701000244	1/28/2026
VEN000920	Huntington National Bank	Huntington National Bank	APP135208	1/28/2026	701008131	PAYROLL-EMPLOYER'S	FICA	32,923.19	701000243	1/28/2026
VEN000920	Huntington National Bank	Huntington National Bank	APP135208	1/28/2026	701008132	PAYROLL-EMPLOYER'S	Medicare	18,857.07	701000243	1/28/2026
VEN000920	Huntington National Bank	Huntington National Bank	APP135208	1/28/2026	701008921	PAYROLL-FEDERAL	Federal	127,913.51	701000243	1/28/2026
VEN000920	Huntington National Bank	Huntington National Bank	APP135208	1/28/2026	701008922	PAYROLL-EMPLOYEE FICA	FICA	32,923.12	701000243	1/28/2026
VEN000920	Huntington National Bank	Huntington National Bank	APP135208	1/28/2026	701008922	PAYROLL-EMPLOYEE FICA	Medicare	18,857.15	701000243	1/28/2026
VEN000959	Indiana Dept Of Revenue	Indiana Dept Of Revenue	APP135209	1/28/2026	701008923	PAYROLL-STATE	State	36,005.42	701000245	1/28/2026
VEN000959	Indiana Dept Of Revenue	Indiana Dept Of Revenue	APP135209	1/28/2026	701008923	PAYROLL-STATE	COIT	18,074.33	701000245	1/28/2026
VEN001537	Payroll	Payroll	APP135245	1/27/2026	701008110	PAYROLL-NET SALARIES	net	951,824.68	701000246	1/27/2026
VEN012663	Empower	Empower	APP135257	1/29/2026	701008931	PAYROLL-401A MATCHING-	Contributions and loans	66,987.83	701000249	1/29/2026
VEN012663	Empower	Empower	APP135261	1/29/2026	701008931	PAYROLL-401A MATCHING-	401a loans	2,158.63	701000248	1/29/2026
VEN010380	Jonathan Mathioudakis	Jonathan Mathioudakis	APP135272	1/30/2026	701008110	PAYROLL-NET SALARIES	Fitness and retro	767.99	19015	1/30/2026
VEN012501	Hamilton County Fire Fighters 4416	Hamilton County Fire Fighters 4416	APP135311	2/2/2026	701008141	PAYROLL-UNION DUES	Union Dues 4416	6,575.43	701000251	2/2/2026
VEN012501	Hamilton County Fire Fighters 4416	Hamilton County Fire Fighters 4416	APP135312	2/2/2026	701008141	PAYROLL-UNION DUES	Union Dues WFD	125.00	701000250	2/2/2026
VEN001736	Sam Peterson	Sam Peterson	APP135408	2/3/2026	701008110	PAYROLL-NET SALARIES	Pay	213.00	19018	2/3/2026
VEN001550	PERF	PERF	APP135494	1/29/2026	701008133	PAYROLL-PERF	Civilian PERF	75,786.02		
		<b>Subtotal for Clerk Treasurer</b>						<b>1,403,503.39</b>		
		<b>Subtotal for Fund 701 Payroll</b>						<b>1,403,503.39</b>		
900	Stormwater									

Fund No.	Fund Name	Buy-From Vendor Name	Invoice No.	Date	G/L Acct.	G/L Account Name	Description	Amount	Check No.	Check Date
900	Stormwater									
	Stormwater									
	VEN001537	Payroll	APP135247	1/27/2026	900016111	STORM-SALARY	sal	23,159.48	900000444	1/27/2026
	VEN001537	Payroll	APP135247	1/27/2026	900016120	STORM-FICA/MEDICARE	fica	1,367.96	900000444	1/27/2026
	VEN001537	Payroll	APP135247	1/27/2026	900016120	STORM-FICA/MEDICARE	med	319.92	900000444	1/27/2026
	VEN001537	Payroll	APP135247	1/27/2026	900016121	STORM-PERF	perf	3,288.64	900000444	1/27/2026
	VEN012663	Empower	APP135264	1/29/2026	900016125	STORM-401A MATCHING	401a Match	881.23		
	VEN012815	Sherrae Davis	APP135361	2/3/2026	900016370	STORMWATER-REFUND		13.83		
	VEN012815	Sherrae Davis	APP135361	2/3/2026	900016370	STORMWATER-REFUND	OVER PAYMENT	56.82		
	VEN012816	Jarhead Holdings LLC	APP135362	2/3/2026	900016370	STORMWATER-REFUND	OVER PAYMENT	519.03		
	VEN012817	Tom Steele	APP135363	2/3/2026	900016370	STORMWATER-REFUND		18.90		
	VEN012817	Tom Steele	APP135363	2/3/2026	900016370	STORMWATER-REFUND	OVER PAYMENT	33.82		
	VEN012818	Michael Donlan	APP135364	2/3/2026	900016370	STORMWATER-REFUND	OVER PAYMENT	272.81		
	VEN012820	Mark Schutte	APP135365	2/3/2026	900016370	STORMWATER-REFUND	OVER PAYMENT	297.36		
	VEN012819	Thomas Mills	APP135366	2/3/2026	900016370	STORMWATER-REFUND		18.90		
	VEN012821	Frank Pruce	APP135367	2/3/2026	900016370	STORMWATER-REFUND	OVER PAYMENT	198.19		
	VEN012822	Kay Zimmerman	APP135368	2/3/2026	900016370	STORMWATER-REFUND		26.22		
	VEN012823	Jeremiah Shipley	APP135369	2/3/2026	900016370	STORMWATER-REFUND		15.10		
	VEN010710	Sondra L Forester	APP135370	2/3/2026	900016370	STORMWATER-REFUND	OVER PAYMENT	84.60		
	VEN012824	Erick Grady	APP135371	2/3/2026	900016370	STORMWATER-REFUND	OVER PAYMENT	326.12		
	VEN012825	Amanda Wochohurka	APP135372	2/3/2026	900016370	STORMWATER-REFUND	OVER PAYMENT	531.05		
	VEN012826	Lynne Lippold	APP135373	2/3/2026	900016370	STORMWATER-REFUND		16.83		
	VEN012827	Kiley Holman	APP135374	2/3/2026	900016370	STORMWATER-REFUND		59.06		
	VEN012827	Kiley Holman	APP135374	2/3/2026	900016370	STORMWATER-REFUND	OVER PAYMENT	258.23		
	VEN012828	Daniel Black	APP135375	2/3/2026	900016370	STORMWATER-REFUND		35.95		
	VEN012829	Chakiny Family LLC	APP135376	2/3/2026	900016370	STORMWATER-REFUND		6.58		
	VEN012830	Susan Sklade	APP135377	2/3/2026	900016370	STORMWATER-REFUND		2.23		
	VEN012831	Sarah Cailis	APP135378	2/3/2026	900016370	STORMWATER-REFUND		18.92		
	VEN012832	Rozet Ghaly	APP135379	2/3/2026	900016370	STORMWATER-REFUND		8.84		
	VEN012833	SD JV LLC	APP135380	2/3/2026	900016370	STORMWATER-REFUND	OVER PAYMENT	60.81		
	VEN012834	Corey Barnett	APP135381	2/3/2026	900016370	STORMWATER-REFUND		2.23		
	VEN012834	Corey Barnett	APP135381	2/3/2026	900016370	STORMWATER-REFUND	OVER PAYMENT	17.19		
	VEN012835	Tammy Lynn Hudson	APP135382	2/3/2026	900016370	STORMWATER-REFUND		118.36		
	VEN012836	David Keller	APP135383	2/3/2026	900016370	STORMWATER-REFUND	OVER PAYMENT	460.42		

**Purchase Invoice Register**

City of Westfield

Report Date Range: 01/22/26..02/04/26

2/4/2026 10:18 AM

Page 15 of 15

WESTFIELD\KGAGNON

Fund No.	Fund Name	Buy-From Vendor Name	Invoice No.	Date	GL Acct.	GL Account Name	Description	Amount	Check No.	Check Date
900	Stormwater									
	Stormwater									
	VEN012837	John Kaniut	APP135384	2/3/2026	900016370	STORMWATER-REFUND		15.10		
	VEN012837	John Kaniut	APP135384	2/3/2026	900016370	STORMWATER-REFUND	OVER PAYMENT	17.19		
	VEN012838	Chase Letters	APP135385	2/3/2026	900016370	STORMWATER-REFUND		19.07		
	VEN003611	White River Alliance	APP135493	2/4/2026	900016350	STORM-	2026 Membership	10,000.00		
	<b>Subtotal for Stormwater</b>							<b>42,546.99</b>		
	<b>Subtotal for Fund 900 Stormwater</b>							<b>42,546.99</b>		
	<b>Posted Invoices Total</b>							<b>7,119,505.51</b>		
<b>Credit Memos</b>										
Vendor No.	Fund Name	Vendor Name	Cr. Memo No.	Date	GL Acct.	GL Account Name	Description	Amount		
101	General									
	Human Resources									
	VEN002177	Indiana Members Credit Union	ACP003114	1/28/2026	101022119	HR-Health/Dental	HR-Health/Dental	357,500.00		
	<b>Subtotal for</b>							<b>357,500.00</b>		
	<b>Subtotal by Fund 101 General</b>							<b>357,500.00</b>		
427	Cum. Capital Development									
	Police									
	VEN006333	Axon Enterprise Inc	ACP003115	1/28/2026	427002472	CCD-PD Equipment Vehicle	CCD-PD Equipment/Vehicle	726.12		
	<b>Subtotal for</b>							<b>726.12</b>		
	<b>Subtotal by Fund 427 Cum. Capital Development</b>							<b>726.12</b>		
	<b>Credit Memo Total</b>							<b>358,226.12</b>		

**Purchase Card Register**

City of Westfield

2/4/2026 1:55 PM

Page 1 of 18

WESTFIELD\KGAGNON

Fund No.	Fund Name	Buy-From Vendor No.	Buy-From Vendor Name	Document No.	Posting Date	G/L Acct.	G/L Account Name	Description	Amount	Check No.	Check Date
101	General										
	<b>Administration</b>										
		852055324	THAI DELIGHT RESTAURANT L	GJPCARD0121646	2/4/2026	101001347	Adm-Promotions	MEETING - FIRE	52.47		
		VEN000679	FAHD AMOCO INC	GJPCARD0121708	2/4/2026	101001334	Adm-	TRAVEL - FUEL	56.48		
		350540872	NATIONAL OIL GAS INC	GJPCARD0121714	2/4/2026	101001334	Adm-	FUEL - TRAVEL	46.97		
		874180750	CHARWEST LLC	GJPCARD0121741	2/4/2026	101001347	Adm-Promotions	MEETING	78.80		
		820544687	AMAZON.COM, INC.	GJPCARD0121752	2/4/2026	101001223	Adm-Office Supplies	COMMUNITY	136.96		
		202936165	AMAZON.COM, INC.	GJPCARD0121755	2/4/2026	101001223	Adm-Office Supplies	OFFICE SUPPLIES	19.94		
		384182109	ZEFFY	GJPCARD0121840	2/4/2026	101001347	Adm-Promotions	WYA - EVENT	402.50		
		922650255	APZ GROUP LLC	GJPCARD0121841	2/4/2026	101001347	Adm-Promotions	LUNCH MEETING	48.41		
		202936165	AMAZON.COM, INC.	GJPCARD0121884	2/4/2026	101001224	Adm-Operating Supplies	OFFICE SUPPLIES	24.24		
		202936165	AMAZON.COM, INC.	GJPCARD0121886	2/4/2026	101001224	Adm-Operating Supplies	OFFICE SUPPLIES	162.49		
		VEN000384	CHICK-FIL-A CORP	GJPCARD0121888	2/4/2026	101001347	Adm-Promotions	LUNCH FOR DIRECTORS	55.79		
		854213732	NORI JAPANESE STEAKHOUS	GJPCARD0121911	2/4/2026	101001347	Adm-Promotions	MAYOR/DCT - LUNCH	43.83		
		991030356	TOAST INC	GJPCARD0121912	2/4/2026	101001347	Adm-Promotions	MEETING	29.98		
		273763414	INDIANAPOLIS PARKING LLC	GJPCARD0121913	2/4/2026	101001334	Adm-	HB101	20.00		
		202936165	AMAZON.COM, INC.	GJPCARD0121933	2/4/2026	101001224	Adm-Operating Supplies	OFFICE SUPPLIES (PW)	22.79		
		454168768	TOAST, INC.	GJPCARD0121955	2/4/2026	101001347	Adm-Promotions	TERRIZACH - MAYOR'S	42.06		
		VEN001820	SQUARE, INC.	GJPCARD0121976	2/4/2026	101001347	Adm-Promotions	MEETING - RESIDENT	9.36		
		820544687	AMAZON.COM, INC.	GJPCARD0121977	2/4/2026	101001223	Adm-Office Supplies	LEADERSHIP BOOK	12.93		
		VEN012363	LinkedIn Corp	GJPCARD0121978	2/4/2026	101001350	Adm-Sub/Dues/Members	SUBSCRIPTION	74.89		
		463115122	PATREON INC	GJPCARD0121980	2/4/2026	101001347	Adm-Promotions	MEMBERSHIP	100.70		
		274749749	TOAST INC	GJPCARD0122029	2/4/2026	101001347	Adm-Promotions	MEETING - FIRE	64.09		
		VEN001820	SQUARE, INC.	GJPCARD0122042	2/4/2026	101001347	Adm-Promotions	MEETING/LORENZO	5.54		
		820544687	AMAZON.COM, INC.	GJPCARD0122052	2/4/2026	101001223	Adm-Office Supplies	OFFICE SUPPLIES	39.44		
		VEN007922	Kroger Limited Partnership	GJPCARD0122103	2/4/2026	101001223	Adm-Office Supplies	SODA FOR	47.12		
		710833125	FLOWER SHOP NETWORK, INC	GJPCARD0122117	2/4/2026	101001347	Adm-Promotions	FLOWERS - WFD -	124.84		
		VEN012173	OPENAI	GJPCARD0122122	2/4/2026	101001349	Adm-Services	OPENAI CHAPGPT	20.00		
			<b>Subtotal for Administration</b>						<b>1,742.62</b>		
			<b>Police</b>								
		351696078	AUTOMOTIVE ACTION II INC	GJPCARD0121638	2/4/2026	101002360	Police-Vehicle Repair	TIRE REPLACEMENT	345.52		
		800874694	CARDIO PARTNERS INC	GJPCARD0121648	2/4/2026	101002334	Police-	165LB MANIKIN	1,867.95		
		832916592	PEAK PARKING, LP	GJPCARD0121650	2/4/2026	101002334	Police-	PARKING FOR WINTER	13.00		
		202936165	AMAZON.COM, INC.	GJPCARD0121652	2/4/2026	101002355	Police-K-9 Maint	K9 LIGHTS SAFETY	24.99		

**Purchase Card Register**

City of Westfield

2/4/2026 1:55 PM

Page 2 of 18

WESTFIELD\KGAGNON

Buy-From Vendor No.	Buy-From Vendor Name	Document No.	Posting Date	G/L Acct.	G/L Account Name	Description	Amount	Check No.	Check Date
<b>101</b>	<b>General</b>								
<b>Police</b>									
202936165	AMAZON.COM, INC.	GJPCARD0121653	2/4/2026	101002355	Police-K-9 Maint	K9 SAFETY LIGHTS	49.98		
820544687	AMAZON.COM, INC.	GJPCARD0121655	2/4/2026	101002224	Police-Operating Supplies	COFFEE ORDER	95.82		
202936165	AMAZON.COM, INC.	GJPCARD0121656	2/4/2026	101002334	Police-	REFUND FOR SHOT	-329.97		
470979240	MEYER DISTRIBUTING PARTNE	GJPCARD0121665	2/4/2026	101002360	Police-Vehicle Repair	BATTERIES FOR POOL	389.36		
161367664	OTIS PRODUCTS INC	GJPCARD0121668	2/4/2026	101002334	Police-	CLEANING SYSTEM	119.58		
832916592	PEAK PARKING, LP	GJPCARD0121673	2/4/2026	101002334	Police-	PARKING FOR IACP	30.00		
832916592	PEAK PARKING, LP	GJPCARD0121676	2/4/2026	101002334	Police-	PARKING FOR IACP	30.00		
383555823	FBI NATIONAL ACADEMY ASSO	GJPCARD0121677	2/4/2026	101002350	Police-Subscriptions/Dues	FBI DUES- DINE	145.00		
202936165	AMAZON.COM, INC.	GJPCARD0121680	2/4/2026	101002334	Police-	PLACE TABLE CARDS	41.98		
832916592	PEAK PARKING, LP	GJPCARD0121685	2/4/2026	101002334	Police-	PARKING FOR IACP	30.00		
454168768	TOAST, INC.	GJPCARD0121703	2/4/2026	101002334	Police-	NEW SGT TRAINING	256.42		
770034661	INTUIT PAYMENT SOLUTIONS,	GJPCARD0121723	2/4/2026	101002334	Police-	HOST FEE- EVENT	1,047.00		
201665019	FACEBOOK INC.	GJPCARD0121727	2/4/2026	101002349	Police-Services	FACEBOOK	69.64		
470979240	MEYER DISTRIBUTING PARTNE	GJPCARD0121732	2/4/2026	101002360	Police-Vehicle Repair	REPLACEMENT VEHICLE	176.48		
VEN001883	Target Corporation	GJPCARD0121753	2/4/2026	101002224	Police-Operating Supplies	COFFEE FOR OFFICE	21.49		
202936165	AMAZON.COM, INC.	GJPCARD0121756	2/4/2026	101002224	Police-Operating Supplies	STANDING DESK	99.99		
384061754	ARLO TECHNOLOGIES, INC.	GJPCARD0121757	2/4/2026	101002350	Police-Subscriptions/Dues	MONTHLY STATEMENT	61.95		
742158707	NATIONAL ANIMAL CARE AND	GJPCARD0121763	2/4/2026	101002350	Police-Subscriptions/Dues	NACA MEMBERSHIP	25.00		
560748358	LOWES COMPANIES, INC.	GJPCARD0121770	2/4/2026	101002224	Police-Operating Supplies	HEATER FOR	39.98		
844332073	WESTFIELD ACE, LLC	GJPCARD0121785	2/4/2026	101002224	Police-Operating Supplies	BATTERIES AND	161.58		
VEN002022	UNITED STATES POSTAL SERV	GJPCARD0121786	2/4/2026	101002349	Police-Services	SHIPPING FOR BMW	11.95		
011111111	SHOPIFY PAYMENTS (USA) IN	GJPCARD0121802	2/4/2026	101002334	Police-	WOODS SOCIAL MEDIA	225.00		
202936165	AMAZON.COM, INC.	GJPCARD0121808	2/4/2026	101002224	Police-Operating Supplies	DRY ERASE CLEANER	8.99		
202936165	AMAZON.COM, INC.	GJPCARD0121812	2/4/2026	101002224	Police-Operating Supplies	ENVELOPES AND SD	95.67		
202936165	AMAZON.COM, INC.	GJPCARD0121819	2/4/2026	101002224	Police-Operating Supplies	DRY ERASE MARKERS	19.99		
842235842	FTD, LLC	GJPCARD0121822	2/4/2026	101002347	Police-Promotions	FLOWERS FOR DAVIN	128.39		
742270626	TEXAS AM ENGINEERING EXT	GJPCARD0121842	2/4/2026	101002334	Police-	TUITION AND	1,570.00		
VEN009277	Neison and Co LLC	GJPCARD0121862	2/4/2026	101002229	Police-Uniforms	HERO'S PRIDE SGT	335.00		
202936165	AMAZON.COM, INC.	GJPCARD0121865	2/4/2026	101002224	Police-Operating Supplies	STANDING DESK	161.49		
471129673	MOS EQUIPMENT	GJPCARD0121870	2/4/2026	101002224	Police-Operating Supplies	MISSION DARKNESS	208.00		
992118289	GIL TACOS LLC	GJPCARD0121871	2/4/2026	101002347	Police-Promotions	ISP LUNCH- DINE	48.27		
202936165	AMAZON.COM, INC.	GJPCARD0121920	2/4/2026	101002224	Police-Operating Supplies	DESK CHAIR- DUGGER	189.99		

**Purchase Card Register**

City of Westfield

2/4/2026 1:55 PM

Page 3 of 18

WESTFIELD\KGAGNON

Fund No.	Fund Name	Buy-From Vendor Name	Buy-From Vendor Name	Document No.	Posting Date	G/L Acct.	G/L Account Name	Description	Amount	Check No.	Check Date
101	General										
		<b>Police</b>									
		VEN001046	ISOA	GJPCARD0121922	2/4/2026	101002334	Police-	DUGGER- ONE DAY	200.00		
		721465486	RAISING CANE'S RESTAURANT	GJPCARD0121937	2/4/2026	101002334	Police-	FOOD DURING	16.67		
		202936165	AMAZON.COM, INC.	GJPCARD0121938	2/4/2026	101002224	Police-Operating Supplies	MAILBOXES FOR	19.47		
		650612863	NASRO	GJPCARD0121950	2/4/2026	101002334	Police-	NASRO REGISTRATION	550.00		
		VEN001333	MEIJER	GJPCARD0121951	2/4/2026	101002334	Police-	HOSTED TRAINING	39.24		
		470979240	MEYER DISTRIBUTING PARTNE	GJPCARD0121987	2/4/2026	101002360	Police-Vehicle Repair	PAXTON REPLACEMENT	130.90		
		472511261	NEW BEGINNING RESTAURANTS	GJPCARD0122000	2/4/2026	101002334	Police-	FOOD DURING	16.67		
		310813395	PLANK'S GARDEN INC	GJPCARD0122001	2/4/2026	101002334	Police-	FOOD DURING	22.69		
		VEN000384	CHICK-FIL-A CORP	GJPCARD0122002	2/4/2026	101002334	Police-	FOOD DURING	12.83		
		VEN000942	Imagery LLC	GJPCARD0122006	2/4/2026	101002229	Police-Uniforms	SHIRT ORDER- ADAMS	766.38		
		392877676	TOAST INC	GJPCARD0122008	2/4/2026	101002334	Police-	FOOD DURING	15.50		
		202597227	GOOGLE PAYMENT CORP.	GJPCARD0122024	2/4/2026	101002349	Police-Services	MONTHLY STATEMENT	92.98		
		011111111	SHOIFY PAYMENTS (USA) IN	GJPCARD0122041	2/4/2026	101002334	Police-	SOCIAL MEDIA AND	900.00		
		530227813	INTERNATIONAL ASSOCIATIO	GJPCARD0122057	2/4/2026	101002350	Police-Subscriptions/Dues	GRIMES IACP	220.00		
		530227813	INTERNATIONAL ASSOCIATIO	GJPCARD0122067	2/4/2026	101002334	Police-	KEEN CONFERENCE-	500.00		
		530227813	INTERNATIONAL ASSOCIATIO	GJPCARD0122068	2/4/2026	101002350	Police-Subscriptions/Dues	KEEN ACTIVE	220.00		
		383555823	FBI NATIONAL ACADEMY ASSO	GJPCARD0122073	2/4/2026	101002350	Police-Subscriptions/Dues	GRIMES MEMBERSHIP	145.00		
		237326896	INDIANA ASSOCIATION OF CH	GJPCARD0122074	2/4/2026	101002334	Police-	GRIMES WINTER	350.00		
		611652239	INDIANA SCHOOL RESOURCE O	GJPCARD0122088	2/4/2026	101002350	Police-Subscriptions/Dues	INSROA MEMBERSHIPS	468.00		
		770433330	FEDEX OFFICE AND PRINT SE	GJPCARD0122096	2/4/2026	101002349	Police-Services	SHIPPING FOR	51.56		
		237326896	INDIANA ASSOCIATION OF CH	GJPCARD0122097	2/4/2026	101002334	Police-	IACP CONFERENCE-	350.00		
		383555823	FBI NATIONAL ACADEMY ASSO	GJPCARD0122099	2/4/2026	101002350	Police-Subscriptions/Dues	KEEN- FBINAA	145.00		
		237326896	INDIANA ASSOCIATION OF CH	GJPCARD0122100	2/4/2026	101002334	Police-	KEEN WINTER	350.00		
		237326896	INDIANA ASSOCIATION OF CH	GJPCARD0122101	2/4/2026	101002350	Police-Subscriptions/Dues	MEMBERSHIP RENEWAL	350.00		
		621482048	AUTOZONE	GJPCARD0122113	2/4/2026	101002360	Police-Vehicle Repair	REPAIRS ON HARRELL	25.99		
		VEN003173	AMAZON MKTPLACE	GJPCARD0122123	2/4/2026	101002224	Police-Operating Supplies	AMAZON MKTPL	11.56		
			<b>Subtotal for Police</b>						<b>13,785.92</b>		
			<b>Economic and Community Development</b>								
		VEN000643	ENTREPRENEURIAL RES	GJPCARD0121649	2/4/2026	101003334	ECD-	CAREER FAIR LUNCH -	35.26		
		VEN001810	SOUTHWEST AIRLINES CO	GJPCARD0121731	2/4/2026	101003334	ECD-	TRAVEL_FIREACADEMY	327.48		
		770510487	PAYPAL	GJPCARD0121776	2/4/2026	101003349	ECD-Services	SERVICES_HCR_ANNEX	30.39		
		VEN000946	IN BMV VEHICLE SER	GJPCARD0121821	2/4/2026	101003350	ECD-Subscriptions/Dues	DUES_PLA GROUP 2	125.31		

**Purchase Card Register**

City of Westfield

2/4/2026 1:55 PM

Page 4 of 18

WESTFIELD\KGAGNON

Fund No.	Fund Name	Buy-From Vendor Name	Document No.	Posting Date	G/L Acct.	G/L Account Name	Description	Amount	Check No.	Check Date
101	General									
		<b>Economic and Community Development</b>								
		300154226 AMERICAN ASSOCIATION OF	GJPCARD0121875	2/4/2026	101003350	ECD-Subscriptions/Dues	MEMBERSHIP_AAN_CLA	19.00		
		770510487 PAYPAL	GJPCARD0122038	2/4/2026	101003349	ECD-Services	SERVICES_HCR_APCAN	46.35		
		770510487 PAYPAL	GJPCARD0122039	2/4/2026	101003349	ECD-Services	SERVICES_HCR_2026ME	54.73		
		770510487 PAYPAL	GJPCARD0122040	2/4/2026	101003349	ECD-Services	SERVICES_HCR_BZA_30	30.57		
		462652392 PALO ALTO DELIVERY INC.	GJPCARD0122076	2/4/2026	101003349	ECD-Services	TROTT PCARD REIMB	18.29		
		<b>Subtotal for Economic and Community Development</b>						<b>687.38</b>		
		<b>F and E</b>								
		VEND001337 Menards	GJPCARD0121667	2/4/2026	101004343	F and E-Building Maint	SHOP DOOR SEAL	41.44		
		351759190 FLAG AND BANNER CO INC	GJPCARD0121697	2/4/2026	101004343	F and E-Building Maint	FLAG REPAIR	239.17		
		844332073 WESTFIELD ACE, LLC	GJPCARD0121709	2/4/2026	101004343	F and E-Building Maint	3 DRAWER TOOL BOX	200.54		
		844332073 WESTFIELD ACE, LLC	GJPCARD0121739	2/4/2026	101004334	F and E-Travel/Training	WAL MOUNT PLATE AND	59.36		
		205406734 SPOTON TRANSACT LLC	GJPCARD0121758	2/4/2026	101004347	F and E-Promotions	LUNCH MEETING FOR	65.59		
		VEND001337 Menards	GJPCARD0121772	2/4/2026	101004334	F and E-Travel/Training	TOOLS AND A	79.18		
		VEND10839 Eckart LLC	GJPCARD0121781	2/4/2026	101004343	F and E-Building Maint	PARTS FOR LITE	76.37		
		VEND10839 Eckart LLC	GJPCARD0121817	2/4/2026	101004343	F and E-Building Maint	PSB LIGHT BULBS	83.70		
		VEND10839 Eckart LLC	GJPCARD0121818	2/4/2026	101004343	F and E-Building Maint	PW LIGHT BULBS	34.86		
		VEND002125 Wheeling Park Commission	GJPCARD0121830	2/4/2026	101004334	F and E-Travel/Training	BREAKFAST AT EVENT	15.13		
		VEND000135 APPLE, INC. USA RETAIL	GJPCARD0121832	2/4/2026	101004347	F and E-Promotions	APPLE MUSIC	10.99		
		310785108 WENDY'S INTERNATIONAL INC	GJPCARD0121833	2/4/2026	101004334	F and E-Travel/Training	SEMINAR EXPENSE	22.04		
		VEND002125 Wheeling Park Commission	GJPCARD0121838	2/4/2026	101004334	F and E-Travel/Training	SEMINAR EXPENSE	200.39		
		202936165 AMAZON.COM, INC.	GJPCARD0121863	2/4/2026	101004224	F and E- Operating Supplies	F and E-Operating	55.80		
		VEND000800 Grainger	GJPCARD0121864	2/4/2026	101004343	F and E-Building Maint	PSB THERMOSTAT	248.18		
		VEND002125 Wheeling Park Commission	GJPCARD0121879	2/4/2026	101004334	F and E-Travel/Training	BREAKFAST AT EVENT	8.58		
		340526850 SHERWIN WILLIAMS CO	GJPCARD0121880	2/4/2026	101004343	F and E-Building Maint	PAINT FOR OFFICE	6.79		
		251202108 SHEETZ INC	GJPCARD0121882	2/4/2026	101004334	F and E-Travel/Training	SEMINAR EXPENSE -	42.19		
		521234223 TRICOR DIRECT INC	GJPCARD0121885	2/4/2026	101004343	F and E-Building Maint	CSC DOOR SIGNS	32.17		
		340526850 SHERWIN WILLIAMS CO	GJPCARD0121899	2/4/2026	101004343	F and E-Building Maint	PAINT FOR OFFICE	89.20		
		VEND002125 Wheeling Park Commission	GJPCARD0121905	2/4/2026	101004334	F and E-Travel/Training	BREAKFAST AT EVENT	7.80		
		VEND002022 UNITED STATES POSTAL SERV	GJPCARD0121906	2/4/2026	101004347	F and E-Promotions	CERTIFIED MAIL FOR	21.18		
		851332059 NHB LLC	GJPCARD0121907	2/4/2026	101004334	F and E-Travel/Training	SEMINAR EXPENSE	110.00		
		521234223 TRICOR DIRECT INC	GJPCARD0121914	2/4/2026	101004343	F and E-Building Maint	CSC DOOR SIGNS	26.15		

**Purchase Card Register**

City of Westfield

2/4/2026 1:55 PM

Page 5 of 18

WESTFIELD\KGAGNON

Fund No.	Fund Name	Buy-From Vendor No.	Buy-From Vendor Name	Document No.	Posting Date	G/L Acct.	G/L Account Name	Description	Amount	Check No.	Check Date
101	General										
	<b>F and E</b>										
		202936165	AMAZON.COM, INC.	GJPCARD0121918	2/4/2026	101004349	F and E-Services	KELLEY'S REMODELED	288.00		
		851332059	NHB LLC	GJPCARD0121929	2/4/2026	101004334	F and E-Travel/Training	SEMINAR EXPENSE	55.00		
		202936165	AMAZON.COM, INC.	GJPCARD0121932	2/4/2026	101004349	F and E-Services	KELLEY'S REMODELED	804.98		
		202936165	AMAZON.COM, INC.	GJPCARD0121934	2/4/2026	101004349	F and E-Services	KELLEY'S REMODELED	138.00		
		202936165	AMAZON.COM, INC.	GJPCARD0121935	2/4/2026	101004349	F and E-Services	KELLEY'S REMODELED	151.99		
		VEN006898	Supply Warehouse Inc	GJPCARD0121936	2/4/2026	101004343	F and E-Building Maint	CSC / PW CLEANING	259.56		
		VEN002125	Wheeling Park Commission	GJPCARD0121947	2/4/2026	101004334	F and E-Travel/Training	SEMINAR EXPENSE	30.44		
		870282025	CRICUT, INC.	GJPCARD0121949	2/4/2026	101004347	F and E-Promotions	CRICUT SUBSCRIPTION	102.59		
		VEN001337	Menards	GJPCARD0121970	2/4/2026	101004343	F and E-Building Maint	LOW TEMP	24.99		
		452342647	SOUTHERN ROCK RESTAURANT	GJPCARD0121973	2/4/2026	101004334	F and E-Travel/Training	SEMINAR EXPENSE	46.04		
		844332073	WESTFIELD ACE, LLC	GJPCARD0121985	2/4/2026	101004343	F and E-Building Maint	SANDING SPONGE AND	9.52		
		VEN001337	Menards	GJPCARD0121995	2/4/2026	101004343	F and E-Building Maint	PLUMBING SUPPLIES	13.27		
		770034661	INTUIT PAYMENT SOLUTIONS,	GJPCARD0121999	2/4/2026	101004343	F and E-Building Maint	OVERHEAD DOOR	2,542.16		
		800678125	BPI ENTERPRISES, LLC	GJPCARD0122010	2/4/2026	101004343	F and E-Building Maint	STATION 81 OVERHEAD	136.35		
		VEN001337	Menards	GJPCARD0122025	2/4/2026	101004343	F and E-Building Maint	OFFICE COAT RACKS	203.18		
		VEN001333	MEIJER	GJPCARD0122036	2/4/2026	101004347	F and E-Promotions	SUPPLIES FOR ALL	11.98		
		844332073	WESTFIELD ACE, LLC	GJPCARD0122047	2/4/2026	101004343	F and E-Building Maint	FLUSH HANDLE CSC	11.69		
		VEN002171	Zesco	GJPCARD0122075	2/4/2026	101004343	F and E-Building Maint	DISHWASHER	684.52		
		202936165	AMAZON.COM, INC.	GJPCARD0122098	2/4/2026	101004347	F and E-Promotions	WALL HANGING FOR	48.00		
		262104214	WIX.COM LUXEMBOURG SARL	GJPCARD0122104	2/4/2026	101004350	F and E-Subscriptions/Dues	BOOM FORM FOR WIX	119.88		
		844332073	WESTFIELD ACE, LLC	GJPCARD0122105	2/4/2026	101004343	F and E-Building Maint	ICE MELT FOR CSC	14.99		
		201665019	FACEBOOK INC.	GJPCARD0122107	2/4/2026	101004347	F and E-Promotions	FACEBOOK AD FOR WIL	149.99		
		202936165	AMAZON.COM, INC.	GJPCARD0122116	2/4/2026	101004343	F and E-Building Maint	WATER FILTERS	99.99		
			<b>Subtotal for F and E</b>						<b>7,723.91</b>		
	<b>Parks</b>										
		820544687	AMAZON.COM, INC.	GJPCARD0121718	2/4/2026	101005472	Parks-Equipment	WORK BOOTS SALT	466.26		
		202936165	AMAZON.COM, INC.	GJPCARD0121766	2/4/2026	101005472	Parks-Equipment	WADERS	130.28		
		933355248	PERSEUS PAYMENTS	GJPCARD0121848	2/4/2026	101005224	Parks-Operating Supplies	CONTROLLER FOR SALT	278.16		
		560748358	LOWES COMPANIES, INC.	GJPCARD0121889	2/4/2026	101005224	Parks-Operating Supplies	TARPS AND HARDWARE	347.89		
		560748358	LOWES COMPANIES, INC.	GJPCARD0121942	2/4/2026	101005224	Parks-Operating Supplies	SHRINK WRAP	89.94		
		351262570	MORE FARM STORE INC	GJPCARD0121960	2/4/2026	101005472	Parks-Equipment	KUBOTA SERVICE	787.59		
		351262570	MORE FARM STORE INC	GJPCARD0122019	2/4/2026	101005472	Parks-Equipment	KUBOTA PARTS	875.25		

**Purchase Card Register**

City of Westfield

2/4/2026 1:55 PM

Page 6 of 18

WESTFIELDKAGNON

Fund No.	Fund Name	Buy-From Vendor Name	Document No.	Posting Date	G/L Acct.	G/L Account Name	Description	Amount	Check No.	Check Date
101	General									
	<b>Parks</b>									
		560748358 LOWES COMPANIES, INC.	GJPCARD0122055	2/4/2026	101005224	Parks-Operating Supplies	SHRINK WRAP	41.92		
		901016978 ASPIRE PROPERTY INTELLIGE	GJPCARD0122077	2/4/2026	101005224	Parks-Operating Supplies	PROPERTY INTEL	84.15		
		560748358 LOWES COMPANIES, INC.	GJPCARD0122084	2/4/2026	101005224	Parks-Operating Supplies	LIGHT BULBS	44.98		
		VEN008165 KROGER	GJPCARD0122124	2/4/2026	101005347	Parks-Promotion	KROGER	26.97		
		<b>Subtotal for Parks</b>						<b>3,173.39</b>		
	<b>Economic Dev</b>									
		770510487 PAYPAL	GJPCARD0121690	2/4/2026	101006347	Economic Dev-Promotions	INDUSTRY LUNCHEON	65.00		
		300103185 FULLSTEAM OPERATIONS LLC	GJPCARD0121691	2/4/2026	101006334	Economic Dev-Travel/Training	CONFERENCE FEE -	100.00		
		300103185 FULLSTEAM OPERATIONS LLC	GJPCARD0121692	2/4/2026	101006350	Economic Dev-Subscrip/Dues	MEMBERSHIP DUES -	90.00		
		852055324 THAI DELIGHT RESTAURANT L	GJPCARD0121725	2/4/2026	101006347	Economic Dev-Promotions	WELCOME LUNCH WITH	34.32		
		VEN001820 SQUARE, INC.	GJPCARD0121735	2/4/2026	101006347	Economic Dev-Promotions	COFFEE MEETING WITH	2.73		
		VEN001820 SQUARE, INC.	GJPCARD0121790	2/4/2026	101006347	Economic Dev-Promotions	INTRODUCTORY	5.90		
		811317378 CLEVELAND CIRCLE HOTEL LE	GJPCARD0121794	2/4/2026	101006334	Economic Dev-Travel/Training	TRAVEL - HOTEL ROOM	29.13		
		VEN001820 SQUARE, INC.	GJPCARD0121795	2/4/2026	101006347	Economic Dev-Promotions	COFFEE MEETING WITH	8.63		
		VEN000908 HOST INTERNATIONAL INC	GJPCARD0121811	2/4/2026	101006347	Economic Dev-Promotions	TRAVEL - MEALS	5.56		
		833954706 SSP AMERICA IND ,LLC	GJPCARD0121813	2/4/2026	101006334	Economic Dev-Travel/Training	TRAVEL - MEALS FOR	54.18		
		331688749 UNITED BRANDS TROP CARMEL	GJPCARD0121820	2/4/2026	101006347	Economic Dev-Promotions	GRAND PARK DISTRICT	85.92		
		VEN001820 SQUARE, INC.	GJPCARD0121831	2/4/2026	101006347	Economic Dev-Promotions	COFFEE MEETING WITH	4.82		
		911325671 STARBUCKS CORPORATION	GJPCARD0121867	2/4/2026	101006347	Economic Dev-Promotions	COFFEE MEETING WITH	6.72		
		VEN002003 TRUSTEES OF INDIANA UNIVE	GJPCARD0121887	2/4/2026	101006334	Economic Dev-Travel/Training	PARKING - CIRDA	5.00		
		811317378 CLEVELAND CIRCLE HOTEL LE	GJPCARD0121915	2/4/2026	101006334	Economic Dev-Travel/Training	TRAVEL - HOTEL;	144.39		
		VEN002029 URBAN LAND INSTITUTE	GJPCARD0121917	2/4/2026	101006350	Economic Dev-Subscrip/Dues	ULI PLACEMAKING	1,075.00		
		454168768 TOAST, INC.	GJPCARD0121954	2/4/2026	101006347	Economic Dev-Promotions	ECDEV DEPARTMENT	138.68		
		990390353 FLOWER CHILD HOLDING	GJPCARD0121966	2/4/2026	101006347	Economic Dev-Promotions	LUNCH MEETING WITH	18.75		
		VEN000090 AMERICAN AIRLINES	GJPCARD0121991	2/4/2026	101006334	Economic Dev-Travel/Training	TRAVEL - AIRFARE;	957.00		
		205406734 SPOTON TRANSACT LLC	GJPCARD0121994	2/4/2026	101006347	Economic Dev-Promotions	LUNCH MEETING WITH	45.72		
		VEN001476 Office Depot	GJPCARD0121996	2/4/2026	101006347	Economic Dev-Promotions	OFFICE CHAIR FOR	223.62		
		854213732 NORI JAPANESE STEAKHOUS	GJPCARD0122027	2/4/2026	101006347	Economic Dev-Promotions	LUNCH MEETING WITH	43.01		
		VEN002029 URBAN LAND INSTITUTE	GJPCARD0122061	2/4/2026	101006350	Economic Dev-Subscrip/Dues	ULI TRENDS EVENT	75.00		
		VEN001820 SQUARE, INC.	GJPCARD0122062	2/4/2026	101006347	Economic Dev-Promotions	COFFEE MEETING WITH	8.63		
		VEN001820 SQUARE, INC.	GJPCARD0122070	2/4/2026	101006347	Economic Dev-Promotions	COFFEE FOR BASIC	31.06		

**Purchase Card Register**

City of Westfield

2/4/2026 1:55 PM

Page 7 of 18

WESTFIELD\KGAGNON

Fund No.	Fund Name	Buy-From Vendor Name	Document No.	Posting Date	G/L Acct.	G/L Account Name	Description	Amount	Check No.	Check Date
101	General									
	<b>Economic Dev</b>									
	VEN007922	Kroger Limited Partnership	GJPCARD0122080	2/4/2026	101006347	Economic Dev-Promotions	BASICS AND BEST	11.82		
	<b>Subtotal for Economic Dev</b>									
	<b>Informatics</b>									
	202936165	AMAZON.COM, INC.	GJPCARD0121639	2/4/2026	101007451	IT-Computer/Equip	PHONE CASE	22.99		
	202936165	AMAZON.COM, INC.	GJPCARD0121659	2/4/2026	101007451	IT-Computer/Equip	PRIVACY SCREEN	-115.19		
	VEN001337	Menards	GJPCARD0121660	2/4/2026	101007451	IT-Computer/Equip	WPD DRONE WEATHER	75.11		
	863357429	BRIDGESTONE RESTAURANT GR	GJPCARD0121669	2/4/2026	101007347	IT-Promotion	NETWORK SWITCH	63.80		
	202936165	AMAZON.COM, INC.	GJPCARD0121670	2/4/2026	101007451	IT-Computer/Equip	3X IPHONE OTTERBOX	76.95		
	202936165	AMAZON.COM, INC.	GJPCARD0121674	2/4/2026	101007451	IT-Computer/Equip	LANYARDS FOR ID	33.95		
	202936165	AMAZON.COM, INC.	GJPCARD0121675	2/4/2026	101007451	IT-Computer/Equip	1X 20 FT ETHERNET	9.75		
	995003373	ZOHO CORPORATION PRIVATE	GJPCARD0121681	2/4/2026	101007389	IT-Software Licensing	HELPDESK ANNUAL	3,263.00		
	202936165	AMAZON.COM, INC.	GJPCARD0121719	2/4/2026	101007451	IT-Computer/Equip	5X COMPUTER DOCKS	855.40		
	VEN009769	OptiSigns Inc	GJPCARD0121733	2/4/2026	101007389	IT-Software Licensing	WFD DIGITAL SIGNAGE	139.46		
	992524257	MILEIQ	GJPCARD0121736	2/4/2026	101007389	IT-Software Licensing	MONTHLY MILE	250.00		
	820544687	AMAZON.COM, INC.	GJPCARD0121744	2/4/2026	101007451	IT-Computer/Equip	IPAD OTTERBOX	28.99		
	202936165	AMAZON.COM, INC.	GJPCARD0121745	2/4/2026	101007451	IT-Computer/Equip	2X PHONE CASES	52.98		
	VEN009769	OptiSigns Inc	GJPCARD0121759	2/4/2026	101007451	IT-Computer/Equip	WFD DIGITAL SIGN	107.89		
	454168768	TOAST, INC.	GJPCARD0121767	2/4/2026	101007347	IT-Promotion	FIRSTNET REVIEW WITH	68.32		
	770510487	PAYPAL	GJPCARD0121768	2/4/2026	101007389	IT-Software Licensing	ANNUAL CAD RENEWAL	4,483.30		
	351281154	NOBLE ROMANS INC	GJPCARD0121769	2/4/2026	101007347	IT-Promotion	STATION 84 REVIEW	58.62		
	770510487	PAYPAL	GJPCARD0121773	2/4/2026	101007389	IT-Software Licensing	ANNUAL CAD RENEWAL	23,593.50		
	852737595	GIGASHEET	GJPCARD0121783	2/4/2026	101007389	IT-Software Licensing	GIGASHEET	95.00		
	VEN000660	ESRI	GJPCARD0121788	2/4/2026	101007334	IT-Travel/Training/Seminars	ESRI INTERNATIONAL	625.00		
	202936165	AMAZON.COM, INC.	GJPCARD0121815	2/4/2026	101007451	IT-Computer/Equip	RETURN OF 11X	-1,330.89		
	453481385	GO DADDY OPERATING COMPAN	GJPCARD0121825	2/4/2026	101007389	IT-Software Licensing	WEBSITE FEE: 1 YEAR	37.18		
	863357429	BRIDGESTONE RESTAURANT GR	GJPCARD0121835	2/4/2026	101007347	IT-Promotion	GAYLOR EVENT	40.07		
	351281154	NOBLE ROMANS INC	GJPCARD0121836	2/4/2026	101007347	IT-Promotion	WORKING LUNCH: PSB	71.89		
	453481385	GO DADDY OPERATING COMPAN	GJPCARD0121837	2/4/2026	101007389	IT-Software Licensing	WEBSITE FEE: 1 YEAR	167.64		
	843871927	LOS AGAVE	GJPCARD0121850	2/4/2026	101007347	IT-Promotion	GAYLOR EVENT SETUP	105.74		
	202936165	AMAZON.COM, INC.	GJPCARD0121851	2/4/2026	101007451	IT-Computer/Equip	CELL PHONE CASE	47.90		
	992524257	MILEIQ	GJPCARD0121852	2/4/2026	101007389	IT-Software Licensing	NEW LICENSE ADDED	2.27		

**Purchase Card Register**

City of Westfield

2/4/2026 1:55 PM

Page 8 of 18

WESTFIELD\KGAGNON

Fund No.	Fund Name	Buy-From Vendor Name	Document No.	Posting Date	G/L Acct.	G/L Account Name	Description	Amount	Check No.	Check Date
101	General									
	<b>Informatics</b>									
202936165	AMAZON.COM, INC.	GJPCARD0121872	2/4/2026	101007451	IT-Computer/Equip	PHONE CASE.	13.59			
202936165	AMAZON.COM, INC.	GJPCARD0121873	2/4/2026	101007451	IT-Computer/Equip	SCREEN PROTECTOR.	16.99			
202936165	AMAZON.COM, INC.	GJPCARD0121874	2/4/2026	101007451	IT-Computer/Equip	CELL SCREEN	115.19			
202936165	AMAZON.COM, INC.	GJPCARD0121894	2/4/2026	101007451	IT-Computer/Equip	PLUGABLE USB-C	169.15			
202936165	AMAZON.COM, INC.	GJPCARD0121925	2/4/2026	101007451	IT-Computer/Equip	RUGGED CAT6 FOR	383.92			
770510487	PAYPAL	GJPCARD0121928	2/4/2026	101007389	IT-Software Licensing	ANNUAL FTP	569.00			
202936165	AMAZON.COM, INC.	GJPCARD0121941	2/4/2026	101007337	IT-Printing	INK FOR HP 508A PW	239.31			
202936165	AMAZON.COM, INC.	GJPCARD0121953	2/4/2026	101007451	IT-Computer/Equip	1X COMPUTER DOCK	129.99			
863357429	BRIDGESTONE RESTAURANT GR	GJPCARD0121958	2/4/2026	101007347	IT-Promotion	GAYLOR EVENT DAY 2	43.34			
453481385	GO DADDY OPERATING COMPAN	GJPCARD0121959	2/4/2026	101007349	IT-Services	WEBSITE FEE: 1 YEAR	55.18			
811335285	WASABI TECHNOLOGIES	GJPCARD0121967	2/4/2026	101007389	IT-Software Licensing	MONTHLY CLOUD HOT	559.25			
202936165	AMAZON.COM, INC.	GJPCARD0121968	2/4/2026	101007451	IT-Computer/Equip	DRONECONNECTOR	25.89			
202936165	AMAZON.COM, INC.	GJPCARD0121986	2/4/2026	101007451	IT-Computer/Equip	11X LENOVO DOCKS	1,330.89			
820544687	AMAZON.COM, INC.	GJPCARD0121992	2/4/2026	101007451	IT-Computer/Equip	TV FOR CALEB'S OFFICE	248.00			
VEN001360	MICROSOFT CORPORATION	GJPCARD0122013	2/4/2026	101007389	IT-Software Licensing	MICROSOFT FEE: FEE	41.93			
VEN005135	FP Mailing Solutions	GJPCARD0122033	2/4/2026	101007333	IT-Postage	POSTAGE PURCHASE	1,035.00			
VEN001337	Menards	GJPCARD0122034	2/4/2026	101007451	IT-Computer/Equip	GPEC AP MOUNTING	131.89			
202936165	AMAZON.COM, INC.	GJPCARD0122044	2/4/2026	101007451	IT-Computer/Equip	10 PACK 15FT	55.42			
202936165	AMAZON.COM, INC.	GJPCARD0122045	2/4/2026	101007451	IT-Computer/Equip	10 PACK 10FT	36.61			
VEN001261	LOS TOROS MEXICAN RESTAU	GJPCARD0122071	2/4/2026	101007334	IT-Travel/Training/Seminars	MOSS AP ANALYSIS	92.18			
202936165	AMAZON.COM, INC.	GJPCARD0122090	2/4/2026	101007451	IT-Computer/Equip	SWITCH CONSOLE	14.99			
770493581	GOOGLE LLC	GJPCARD0122118	2/4/2026	101007389	IT-Software Licensing	GSUITE COUNCIL	85.54			
	<b>Subtotal for Informatics</b>							<b>38,323.87</b>		
	<b>Clerk Treasurer</b>									
721601420	AFFINIPAY LLC	GJPCARD0121747	2/4/2026	101008347	CT-Promotions	HOUSING WEBINAR	10.00			
202936165	AMAZON.COM, INC.	GJPCARD0121782	2/4/2026	101008224	CT-Operating Supplies	COAT RACK,	86.19			
770510487	PAYPAL	GJPCARD0121891	2/4/2026	101008334	CT-Travel/Training/Seminars	AIM CLASS	85.00			
770510487	PAYPAL	GJPCARD0121892	2/4/2026	101008334	CT-Travel/Training/Seminars	AIM CLASS	85.00			
770510487	PAYPAL	GJPCARD0121893	2/4/2026	101008334	CT-Travel/Training/Seminars	AIM CLASS FOR DEBBY	85.00			
VEN001820	SQUARE, INC.	GJPCARD0122005	2/4/2026	101008347	CT-Promotions	HR/PAYROLL	87.91			
VEN012173	OPENAI	GJPCARD0122125	2/4/2026	101008350	CT-	OPENAI CHATGPT	20.00			
	<b>Subtotal for Clerk Treasurer</b>							<b>459.10</b>		

**Purchase Card Register**

City of Westfield

2/4/2026 1:55 PM

Page 9 of 18

WESTFIELD\KGAGNON

Fund No.	Fund Name	Buy-From Vendor No.	Buy-From Vendor Name	Document No.	Posting Date	G/L Acct.	G/L Account Name	Description	Amount	Check No.	Check Date
101	General										
		<b>Mayor</b>									
		205406734	SPOTON TRANSACT LLC	GJPCARD0121695	2/4/2026	101009347	Mayor-Promotions	LUNCH WITH RESIDENT.	39.00		
		814695314	CHIBA WESTFIELD LLC	GJPCARD0121780	2/4/2026	101009347	Mayor-Promotions	LUNCH MEETING WITH	55.87		
		811317378	CLEVELAND CIRCLE HOTEL LE	GJPCARD0121793	2/4/2026	101009334	Mayor-	HOTEL FOR BOSTON	218.52		
		273763414	INDIANAPOLIS PARKING LLC	GJPCARD0121797	2/4/2026	101009334	Mayor-	PARKING WHILE AT	28.00		
		VEN001820	SQUARE, INC.	GJPCARD0121798	2/4/2026	101009347	Mayor-Promotions	STATE HOUSE MEETING	5.34		
		991030356	TOAST INC	GJPCARD0121799	2/4/2026	101009347	Mayor-Promotions	MEAL DURING BOSTON	24.85		
		VEN000992	INDIANAPOLIS AIRPORT AUTH	GJPCARD0121800	2/4/2026	101009334	Mayor-	BOSTON TRIP PARKING	28.00		
		VEN000908	HOST INTERNATIONAL INC	GJPCARD0121803	2/4/2026	101009347	Mayor-Promotions	COFFEE DURING	15.41		
		421553246	BUDGET RAC SYSTEMS INC	GJPCARD0121810	2/4/2026	101009334	Mayor-	RENTAL CAR FOR	30.66		
		854062397	TOAST INC	GJPCARD0121816	2/4/2026	101009334	Mayor-	MEAL WHILE AT	132.21		
		VEN001820	SQUARE, INC.	GJPCARD0121847	2/4/2026	101009347	Mayor-Promotions	RESIDENT MEETING.	12.71		
		VEN002003	TRUSTEES OF INDIANA UNIVE	GJPCARD0121877	2/4/2026	101009334	Mayor-	PARKING FOR CIRDA	5.00		
		421553246	BUDGET RAC SYSTEMS INC	GJPCARD0121997	2/4/2026	101009334	Mayor-	BOSTON CONFERENCE	79.62		
		VEN000090	AMERICAN AIRLINES	GJPCARD0121998	2/4/2026	101009334	Mayor-	BOSTON CONFERENCE	957.00		
		861088458	BIG HOFFAS SMOKEHOUSE BAR	GJPCARD0122028	2/4/2026	101009347	Mayor-Promotions	LUNCH MEETING -	85.07		
		VEN001820	SQUARE, INC.	GJPCARD0122050	2/4/2026	101009347	Mayor-Promotions	MAYOR'S COFFEE FOR	7.81		
		873249417	SALADWORKS HAMILTON	GJPCARD0122081	2/4/2026	101009347	Mayor-Promotions	MAYOR'S LUNCH FOR	16.89		
		VEN003374	MARATHON PETRO	GJPCARD0122126	2/4/2026	101009334	Mayor-	MARATHON GAS	49.42		
			<b>Subtotal for Mayor</b>						<b>1,791.38</b>		
		<b>Public Works</b>									
		842937741	EL SMITH INVESTMENTS INC	GJPCARD0121658	2/4/2026	101013229	PW-Uniforms	WORK BOOTS FOR	200.00		
		842937741	EL SMITH INVESTMENTS INC	GJPCARD0121666	2/4/2026	101013229	PW-Uniforms	WORK BOOTS FOR	169.99		
		202936165	AMAZON.COM, INC.	GJPCARD0121686	2/4/2026	101013223	PW-Office Supplies	OFFICE SUPPLIES FOR	57.57		
		814397272	TKO INC	GJPCARD0121688	2/4/2026	101013347	PW-Promotions	BREAKFAST FOOD FOR	151.78		
		VEN007922	Kroger Limited Partnership	GJPCARD0121696	2/4/2026	101013347	PW-Promotions	BEVERAGES FOR	54.48		
		362202880	AMERICAN PUBLIC WORKS	GJPCARD0121698	2/4/2026	101013350	PW-Subs/Dues	APWA MEMBERSHIP	1,264.00		
		VEN007922	Kroger Limited Partnership	GJPCARD0121699	2/4/2026	101013347	PW-Promotions	BEVERAGES FOR	43.28		
		853814330	WESTFIELD DONUTS INC	GJPCARD0121700	2/4/2026	101013347	PW-Promotions	DONUTS FOR STREET	122.50		
		934349949	RPM PIZZA MIDWEST II LLC	GJPCARD0121701	2/4/2026	101013347	PW-Promotions	PIZZA FOR STREET	173.73		
		202936165	AMAZON.COM, INC.	GJPCARD0121778	2/4/2026	101013229	PW-Uniforms	THIS IS THE RETURNED	-100.29		
		273763414	INDIANAPOLIS PARKING LLC	GJPCARD0121801	2/4/2026	101013334	PW-Travel/Training/Seminars	PARKING FOR FOLLOW	14.00		
		202936165	AMAZON.COM, INC.	GJPCARD0121809	2/4/2026	101013229	PW-Uniforms	WORK BOOTS FOR	100.29		

**Purchase Card Register**

City of Westfield

2/4/2026 1:55 PM

Page 10 of 18

WESTFIELD\KGAGNON

Fund No.	Fund Name	Buy-From Vendor Name	Document No.	Posting Date	G/L Acct.	G/L Account Name	Description	Amount	Check No.	Check Date
101	General									
	<b>Public Works</b>									
		VEN000771 GFS MARKETPLACE LLC	GJPCARD0121828	2/4/2026	101013347	PW-Promotions	FOOD FOR	250.56		
		VEN008108 Kimball Midwest	GJPCARD0121869	2/4/2026	101013224	PW-Operating Supplies	STOCK, NUTS, BOLTS,	721.14		
		VEN007500 BAMWX LLC	GJPCARD0121876	2/4/2026	101013350	PW-Subs/Dues	MEMBERSHIP FOR	1,310.00		
		VEN000944 IN ASSN CITIES & TOWNS	GJPCARD0121878	2/4/2026	101013334	PW-Travel/Training/Seminars	AIM HANDBOOKS FOR	150.00		
		465339406 BORSHA INC LLC	GJPCARD0121883	2/4/2026	101013347	PW-Promotions	LUNCH W/CD STAFF	140.81		
		261081729 BOOT BARN, INC	GJPCARD0121910	2/4/2026	101013229	PW-Uniforms	BOOTS FOR HOYT, H.	611.93		
		202936165 AMAZON.COM, INC.	GJPCARD0121919	2/4/2026	101013229	PW-Uniforms	WORKS BOOTS FOR	199.95		
		273763414 INDIANAPOLIS PARKING LLC	GJPCARD0121921	2/4/2026	101013334	PW-Travel/Training/Seminars	PARKING FOR	20.00		
		VEN008108 Kimball Midwest	GJPCARD0122003	2/4/2026	101013224	PW-Operating Supplies	WASHERS, NUTS,	465.00		
		454168768 TOAST, INC.	GJPCARD0122014	2/4/2026	101013347	PW-Promotions	STREET DEPARTMENT	59.87		
		<b>Subtotal for Public Works</b>						<b>6,180.59</b>		
	<b>Communications</b>									
		273918344 SKILLSHARE, INC.	GJPCARD0121645	2/4/2026	101020350	Comm-Dues membership	TECHNICAL TRAINING	167.88		
		202936165 AMAZON.COM, INC.	GJPCARD0121647	2/4/2026	101020347	Comm-Promotions	SPACE HEATER FOR	42.28		
		770034661 INTUIT PAYMENT SOLUTIONS,	GJPCARD0121687	2/4/2026	101020347	Comm-Promotions	SOCIAL MEDIA	258.75		
		VEN002063 VISTAPRINT NETHERLANDS NV	GJPCARD0121717	2/4/2026	101020337	Comm-Printing	CITY SERVICES WALL	824.90		
		582554149 THE ROCKET SCIENCE GROUP,	GJPCARD0121724	2/4/2026	101020350	Comm-Dues membership	MONTHLY MAILCHIMP	110.00		
		820544687 AMAZON.COM, INC.	GJPCARD0121740	2/4/2026	101020347	Comm-Promotions	SUPPLIES FOR NEW	14.37		
		990390353 FLOWER CHILD HOLDING	GJPCARD0121743	2/4/2026	101020347	Comm-Promotions	LUNCH MEETING	24.10		
		202936165 AMAZON.COM, INC.	GJPCARD0121762	2/4/2026	101020347	Comm-Promotions	SUPPLIES FOR NEW	32.99		
		204837749 OMNI HOTELS	GJPCARD0121791	2/4/2026	101020334	Comm- Training	HOTEL DEPOSIT FOR	293.18		
		521046350 THE NATIONAL ASSOCIATION	GJPCARD0121792	2/4/2026	101020334	Comm- Training	NAGC CONFERENCE	1,390.00		
		VEN011967 Gannett Indiana Kentucky LocalIQ	GJPCARD0121834	2/4/2026	101020350	Comm-Dues membership	SUBSCRIPTION	19.99		
		831960637 OPENAI OPCO, LLC	GJPCARD0121861	2/4/2026	101020349	Comm-Services	GENERATIVE TEXT	150.00		
		202936165 AMAZON.COM, INC.	GJPCARD0121979	2/4/2026	101020347	Comm-Promotions	PROCLAMATION	22.99		
		205406734 SPOTON TRANSACT LLC	GJPCARD0121982	2/4/2026	101020347	Comm-Promotions	COMMS TEAM LUNCH	112.00		
		VEN001820 SQUARE, INC.	GJPCARD0122046	2/4/2026	101020347	Comm-Promotions	COFFEE MEETING	7.54		
		770510487 PAYPAL	GJPCARD0122087	2/4/2026	101020347	Comm-Promotions	REPORTER AD - ICE	265.00		
		770510487 PAYPAL	GJPCARD0122110	2/4/2026	101020334	Comm- Training	PRSA GEO TRAINING	595.00		
		463165559 AIRBNB PAYMENTS INC	GJPCARD0122120	2/4/2026	101020334	Comm- Training	INADVERTENT CHARGE.	106.81		
		<b>Subtotal for Communications</b>						<b>4,437.78</b>		

**Purchase Card Register**

City of Westfield

2/4/2026 1:55 PM

Page 11 of 18

WESTFIELD\KGAGNON

Fund No.	Fund Name	Buy-From Vendor No.	Buy-From Vendor Name	Document No.	Posting Date	G/L Acct.	G/L Account Name	Description	Amount	Check No.	Check Date	
101	General											
<b>Human Resources</b>												
	VEN000533	DELTA AIRLINES INC	GJPCARD0121760	2/4/2026	101022334	HR- Training	HR-Training		29.00			
	VEN000533	DELTA AIRLINES INC	GJPCARD0121761	2/4/2026	101022334	HR- Training	HR-Training		29.00			
	VEN000533	DELTA AIRLINES INC	GJPCARD0121764	2/4/2026	101022334	HR- Training	HR-Training		29.00			
	VEN000533	DELTA AIRLINES INC	GJPCARD0121765	2/4/2026	101022334	HR- Training	HR-Training		29.00			
	770510487	PAYPAL	GJPCARD0121868	2/4/2026	101022334	HR- Training	HR-Training		235.20			
	454168768	TOAST, INC.	GJPCARD0121881	2/4/2026	101022347	HR- Promotions	HR-Promotions		25.72			
	VEN001820	SQUARE, INC.	GJPCARD0121909	2/4/2026	101022347	HR- Promotions	HR-Promotions		26.16			
	351742510	WELLNESS COUNCIL OF INDIA	GJPCARD0121971	2/4/2026	101022350	HR-Dues membership	20260109 QUIT NOW		400.00			
	350411610	INDIANA CHAMBER OF COMMER	GJPCARD0121972	2/4/2026	101022347	HR- Promotions	HR-Promotions		530.00			
	VEN000533	DELTA AIRLINES INC	GJPCARD0122004	2/4/2026	101022334	HR- Training	HR-Training		420.60			
	VEN000708	FIRST WATCH	GJPCARD0122022	2/4/2026	101022347	HR- Promotions	20260108 ALL TEAM		66.84			
	VEN007922	Kroger Limited Partnership	GJPCARD0122023	2/4/2026	101022347	HR- Promotions	20260108 ORIENTATION		117.76			
	541387365	DOLLAR TREE STORES, INC.	GJPCARD0122030	2/4/2026	101022347	HR- Promotions	20260108 ENGAGEMENT		60.46			
	<b>Subtotal for Human Resources</b>									<b>1,998.74</b>		
	<b>Subtotal for Fund 101 General</b>									<b>83,575.27</b>		

Fund No.	Fund Name	Buy-From Vendor No.	Buy-From Vendor Name	Document No.	Posting Date	G/L Acct.	G/L Account Name	Description	Amount	Check No.	Check Date
103	Fire Operating										
<b>Fire</b>											
	453073013	EZCATER, INC	GJPCARD0121637	2/4/2026	103012334	Fire-Travel/Training/Seminars	OFFSITE TRAINING		496.96		
	1216563227		GJPCARD0121640	2/4/2026	103012350	Fire-Subscriptions/Dues	YRL SUBSCRIPTION		129.99		
	VEN006898	Supply Warehouse Inc	GJPCARD0121641	2/4/2026	103012224	Fire-Operating Supplies	STR82 SUPPLIES		539.32		
	VEN012555	Engraving Awards and Gifts	GJPCARD0121642	2/4/2026	103012347	Fire-Promotions	RETIREE		227.35		
	133139732	TRACTOR SUPPLY CO	GJPCARD0121643	2/4/2026	103012360	Fire-Vehicle Maint	FIXAFLAT		33.16		
	VEN121187	PCard Federal ID-VEN121187 has no	GJPCARD0121657	2/4/2026	103012349	Fire-Services	FEE		0.22		
	202936165	AMAZON.COM, INC.	GJPCARD0121661	2/4/2026	103012224	Fire-Operating Supplies	PF SUPPLIES		150.20		
	654706886		GJPCARD0121662	2/4/2026	103012350	Fire-Subscriptions/Dues	MASTERYOURMEDICS		22.16		
	VEN012555	Engraving Awards and Gifts	GJPCARD0121663	2/4/2026	103012347	Fire-Promotions	RETIREES		1,366.78		
	VEN001333	MEIJER	GJPCARD0121664	2/4/2026	103012334	Fire-Travel/Training/Seminars	OFFSITE TRAINING		162.77		
	833052786	FOAMFRAT LLC	GJPCARD0121672	2/4/2026	103012350	Fire-Subscriptions/Dues	YEARLY SUB		159.99		
	VEN001810	SOUTHWEST AIRLINES CO	GJPCARD0121678	2/4/2026	103012334	Fire-Travel/Training/Seminars	FLIGHT FOR CONFERN		762.60		
	VEN000819	Guest Services	GJPCARD0121679	2/4/2026	103012334	Fire-Travel/Training/Seminars	MEAL TICKET		314.23		

**Purchase Card Register**

City of Westfield

2/4/2026 1:55 PM

Page 12 of 18

WESTFIELD\KGAGNON

Buy-From Vendor No.	Buy-From Vendor Name	Document No.	Posting Date	G/L Acct.	G/L Account Name	Description	Amount	Check No.	Check Date
<b>Fire</b>									
VEN000670	EXPEDIA, INC.	GJPCARD0121682	2/4/2026	103012334	Fire-Travel/Training/Seminars	HOTEL	179.63		
VEN000819	Guest Services	GJPCARD0121683	2/4/2026	103012334	Fire-Travel/Training/Seminars	MEAL TICKET	314.23		
VEN001337	Menards	GJPCARD0121689	2/4/2026	103012224	Fire-Operating Supplies	RETURN	-18.86		
VEN005651	ISFSI	GJPCARD0121693	2/4/2026	103012350	Fire-Subscriptions/Dues	ISFSI	150.00		
452342647	SOUTHERN ROCK RESTAURANT	GJPCARD0121702	2/4/2026	103012347	Fire-Promotions	LUNCH	38.54		
831960637	OPENAI OPCO, LLC	GJPCARD0121704	2/4/2026	103012350	Fire-Subscriptions/Dues	CHATGPT	120.00		
VEN001820	SQUARE, INC.	GJPCARD0121705	2/4/2026	103012334	Fire-Travel/Training/Seminars	CLASS	675.00		
VEN001333	MEIJER	GJPCARD0121706	2/4/2026	103012224	Fire-Operating Supplies	L384	41.77		
VEN001337	Menards	GJPCARD0121707	2/4/2026	103012224	Fire-Operating Supplies	PLUGS E384	30.99		
VEN012842	VAST GIFTS	GJPCARD0121715	2/4/2026	103012224	Fire-Operating Supplies	CHALLENGE COINS	458.00		
351955872	INDIANA UNIVERSITY HEALT	GJPCARD0121716	2/4/2026	103012334	Fire-Travel/Training/Seminars	CLASS	50.00		
VEN001337	Menards	GJPCARD0121722	2/4/2026	103012224	Fire-Operating Supplies	EPOXY ETC	156.98		
311537655	MARATHON PETROLEUM COMPAN	GJPCARD0121728	2/4/2026	103012226	Fire-Vehicle Gas/Supplies	FUEL	40.00		
351955872	INDIANA UNIVERSITY HEALT	GJPCARD0121729	2/4/2026	103012334	Fire-Travel/Training/Seminars	CLASS	50.00		
202936165	AMAZON.COM, INC.	GJPCARD0121737	2/4/2026	103012224	Fire-Operating Supplies	KNEE CONTRAST	449.00		
202936165	AMAZON.COM, INC.	GJPCARD0121738	2/4/2026	103012223	Fire-Office Supplies	CARDSTOCK	29.99		
VEN000667	EVENTBRITE INC.	GJPCARD0121742	2/4/2026	103012334	Fire-Travel/Training/Seminars	CLASS	115.00		
VEN000667	EVENTBRITE INC.	GJPCARD0121748	2/4/2026	103012334	Fire-Travel/Training/Seminars	CLASS	115.00		
011111111	SHOPIFY PAYMENTS (USA) IN	GJPCARD0121749	2/4/2026	103012472	Fire-Equip	RECOVERY EQUIPMENT	459.98		
830846110	ES ACQUISITION LLC	GJPCARD0121750	2/4/2026	103012472	Fire-Equip	TRT EQUIPMENT	1,090.00		
VEN001698	Rogue Fitness	GJPCARD0121751	2/4/2026	103012472	Fire-Equip	GYM/RECOVERY	2,549.78		
131102020	THE NEW YORK TIMES COMPAN	GJPCARD0121754	2/4/2026	103012350	Fire-Subscriptions/Dues	NY TIMES	25.00		
VEN012004	Total Truck Parts	GJPCARD0121771	2/4/2026	103012360	Fire-Vehicle Maint	ABS PART	105.00		
300711910	ACI PAYMENTS INC	GJPCARD0121774	2/4/2026	103012334	Fire-Travel/Training/Seminars	CLASSES	2,084.39		
202936165	AMAZON.COM, INC.	GJPCARD0121775	2/4/2026	103012224	Fire-Operating Supplies	KITCHEN SUPPLIES	22.58		
131878775	NATIONAL FIRE SPRINKLER	GJPCARD0121784	2/4/2026	103012350	Fire-Subscriptions/Dues	NFSA	50.00		
VEN000667	EVENTBRITE INC.	GJPCARD0121789	2/4/2026	103012334	Fire-Travel/Training/Seminars	CLASS	115.00		
870681932	FITNESS EQUIPMENT SERVICE	GJPCARD0121804	2/4/2026	103012472	Fire-Equip	TREADMILL	2,899.99		
VEN006898	Supply Warehouse Inc	GJPCARD0121805	2/4/2026	103012224	Fire-Operating Supplies	ST83 SUPPLIES	690.54		
820544687	AMAZON.COM, INC.	GJPCARD0121807	2/4/2026	103012224	Fire-Operating Supplies	VACUUM	249.99		
310806232	NATIONAL REGISTRY OF EMER	GJPCARD0121824	2/4/2026	103012334	Fire-Travel/Training/Seminars	C. VAHARY	175.00		
202936165	AMAZON.COM, INC.	GJPCARD0121826	2/4/2026	103012223	Fire-Office Supplies	NOTARY STAMP	28.98		

**Purchase Card Register**

City of Westfield

2/4/2026 1:55 PM

Page 13 of 18

WESTFIELDKAGNON

Fund No.	Fund Name	Buy-From Vendor Name	Document No.	Posting Date	G/L Acct.	G/L Account Name	Description	Amount	Check No.	Check Date
103	Fire Operating									
	Fire									
	VEN001820	SQUARE, INC.	GJPCARD0121827	2/4/2026	103012334	Fire-Travel/Training/Seminars	CLASS	100.00		
	365131881	PLAUD LLC	GJPCARD0121829	2/4/2026	103012350	Fire-Subscriptions/Dues	YRL SUB	99.99		
	VEN001985	Traffic Safety Store	GJPCARD0121839	2/4/2026	103012334	Fire-Travel/Training/Seminars	TILLER EQUIPMENT	371.57		
	VEN000992	INDIANAPOLIS AIRPORT AUTH	GJPCARD0121843	2/4/2026	103012334	Fire-Travel/Training/Seminars	PARKING	138.00		
	860802488	ARIZONA FUEL DISTRIBUTOR	GJPCARD0121844	2/4/2026	103012226	Fire-Vehicle Gas/Supplies	FUEL FOR TRAVEL	29.49		
	320585790	SNRE CHAPARRALL III LLC	GJPCARD0121845	2/4/2026	103012334	Fire-Travel/Training/Seminars	HOTEL	1,192.40		
	111998661	AVIS RENT-A-CAR SYS INC	GJPCARD0121846	2/4/2026	103012334	Fire-Travel/Training/Seminars	CAR RENTAL	573.45		
	474423930	INVESTIGATIVE CONCEPTS	GJPCARD0121849	2/4/2026	103012334	Fire-Travel/Training/Seminars	CLASS	360.50		
	454168768	TOAST, INC.	GJPCARD0121856	2/4/2026	103012334	Fire-Travel/Training/Seminars	FOOD PER DIEM	177.65		
	820544687	AMAZON.COM, INC.	GJPCARD0121857	2/4/2026	103012334	Fire-Travel/Training/Seminars	BOOK	47.08		
	820544687	AMAZON.COM, INC.	GJPCARD0121858	2/4/2026	103012334	Fire-Travel/Training/Seminars	TRAINING BOOKS	335.58		
	932238823	OREGAMOS AZ LLC	GJPCARD0121859	2/4/2026	103012334	Fire-Travel/Training/Seminars	FOOD PER DIEM	149.17		
	811730707	FIRE DEPARTMENT SAFETY OF	GJPCARD0121895	2/4/2026	103012334	Fire-Travel/Training/Seminars	CLASS	595.00		
	261233097	STATE DEPARTMENT OF TOXIC	GJPCARD0121896	2/4/2026	103012349	Fire-Services	SERVICE FEE	4.95		
	202936165	AMAZON.COM, INC.	GJPCARD0121898	2/4/2026	103012472	Fire-Equip	LOGITECH	699.51		
	943019135	SAFEWAY INC	GJPCARD0121900	2/4/2026	103012334	Fire-Travel/Training/Seminars	WATERS	7.62		
	202936165	AMAZON.COM, INC.	GJPCARD0121902	2/4/2026	103012244	Fire-Prevention/Public	PUBLIC CPR EQUIP	375.00		
	202936165	AMAZON.COM, INC.	GJPCARD0121903	2/4/2026	103012223	Fire-Office Supplies	LAPTOP BAG	44.99		
	VEN001337	Menards	GJPCARD0121904	2/4/2026	103012472	Fire-Equip	NEW ENG384	123.70		
	320585790	SNRE CHAPARRALL III LLC	GJPCARD0121908	2/4/2026	103012334	Fire-Travel/Training/Seminars	FOOD PER DIEM	148.66		
	264374819	ADVANCED RESCUE SOLUTIONS	GJPCARD0121916	2/4/2026	103012334	Fire-Travel/Training/Seminars	CLASS	775.00		
	264374819	ADVANCED RESCUE SOLUTIONS	GJPCARD0121923	2/4/2026	103012334	Fire-Travel/Training/Seminars	CLASS	775.00		
	264374819	ADVANCED RESCUE SOLUTIONS	GJPCARD0121924	2/4/2026	103012334	Fire-Travel/Training/Seminars	CLASS	775.00		
	820544687	AMAZON.COM, INC.	GJPCARD0121926	2/4/2026	103012224	Fire-Operating Supplies	BATTERIES	25.47		
	820544687	AMAZON.COM, INC.	GJPCARD0121927	2/4/2026	103012223	Fire-Office Supplies	LEGAL BOXES	29.99		
	VEN000946	IN BMV VEHICLE SER	GJPCARD0121939	2/4/2026	103012334	Fire-Travel/Training/Seminars	NOTARY RENEWAL	49.37		
	202936165	AMAZON.COM, INC.	GJPCARD0121940	2/4/2026	103012224	Fire-Operating Supplies	ST83 SUPPLIES	37.96		
	202936165	AMAZON.COM, INC.	GJPCARD0121943	2/4/2026	103012224	Fire-Operating Supplies	PAN	74.96		
	710415188	WAL-MART STORES, INC.	GJPCARD0121944	2/4/2026	103012224	Fire-Operating Supplies	SUPPLIES ST84	142.87		
	844332073	WESTFIELD ACE, LLC	GJPCARD0121945	2/4/2026	103012472	Fire-Equip	NEW ENG384	100.94		
	860222816	LOS OLIVOS MEXICAN PATIO,	GJPCARD0121946	2/4/2026	103012334	Fire-Travel/Training/Seminars	FOOD PER DIEM	114.21		
	454168768	TOAST, INC.	GJPCARD0121952	2/4/2026	103012347	Fire-Promotions	BUSINESS LUNCH	103.34		

**Purchase Card Register**

City of Westfield

2/4/2026 1:55 PM

Page 14 of 18

WESTFIELD\KGAGNON

Fund No.	Fund Name	Buy-From Vendor Name	Document No.	Posting Date	G/L Acct.	G/L Account Name	Description	Amount	Check No.	Check Date
103	Fire Operating									
	Fire									
		300711910 ACI PAYMENTS INC	GJPCARD0121956	2/4/2026	103012334	Fire-Travel/Training/Seminars	J. SHRUM	102.75		
		820544687 AMAZON.COM, INC.	GJPCARD0121957	2/4/2026	103012224	Fire-Operating Supplies	DAISY FOOD	28.47		
		202936165 AMAZON.COM, INC.	GJPCARD0121961	2/4/2026	103012224	Fire-Operating Supplies	ST84 SUPPLIES	143.06		
		300711910 ACI PAYMENTS INC	GJPCARD0121962	2/4/2026	103012334	Fire-Travel/Training/Seminars	J. SHRUM	223.22		
		223407945 AUDIBLE, INC.	GJPCARD0121963	2/4/2026	103012350	Fire-Subscriptions/Dues	AUDIBLE	16.00		
		202936165 AMAZON.COM, INC.	GJPCARD0121964	2/4/2026	103012224	Fire-Operating Supplies	ST83 SUPPLIES	355.06		
		202597227 GOOGLE PAYMENT CORP.	GJPCARD0121965	2/4/2026	103012350	Fire-Subscriptions/Dues	YOUTUBE	133.96		
		VEN001820 SQUARE, INC.	GJPCARD0121969	2/4/2026	103012334	Fire-Travel/Training/Seminars	FOOD PER DIEM	70.65		
		1356613797 AMERICAN HEART ASSOC	GJPCARD0121981	2/4/2026	103012334	Fire-Travel/Training/Seminars	BLS BOOKS ETC	1,359.32		
		VEN000135 APPLE, INC. USA RETAIL	GJPCARD0121988	2/4/2026	103012350	Fire-Subscriptions/Dues	STORAGE	0.99		
		710415188 WAL-MART STORES, INC.	GJPCARD0121990	2/4/2026	103012347	Fire-Promotions	COOKIES	45.82		
		020177030 LIBERTY MUTUAL INSURANCE	GJPCARD0122009	2/4/2026	103012349	Fire-Services	BOND	50.00		
		VEN0000946 IN BMV VEHICLE SER	GJPCARD0122011	2/4/2026	103012349	Fire-Services	JMGUNNING	15.70		
		VEN0000090 AMERICAN AIRLINES	GJPCARD0122012	2/4/2026	103012334	Fire-Travel/Training/Seminars	CHECKED BAGS	35.00		
		VEN001337 Menards	GJPCARD0122015	2/4/2026	103012472	Fire-Equip	RETURN	-155.16		
		VEN0000946 IN BMV VEHICLE SER	GJPCARD0122016	2/4/2026	103012350	Fire-Subscriptions/Dues	JESS NOTARY	74.37		
		922189418 PWW ADVISORY GROUP LLC	GJPCARD0122017	2/4/2026	103012334	Fire-Travel/Training/Seminars	HIPPA -JMGUNNING	1,400.00		
		VEN001337 Menards	GJPCARD0122018	2/4/2026	103012224	Fire-Operating Supplies	BOLTS/SPRAY PAINT	51.04		
		202936165 AMAZON.COM, INC.	GJPCARD0122020	2/4/2026	103012244	Fire-Prevention/Public	CPR TEACHING PACK	375.00		
		VEN006898 Supply Warehouse Inc	GJPCARD0122021	2/4/2026	103012224	Fire-Operating Supplies	ST81 SUPPLIES	786.58		
		VEN0000090 AMERICAN AIRLINES	GJPCARD0122026	2/4/2026	103012334	Fire-Travel/Training/Seminars	CHECKED BAGS	35.00		
		011111111 SHOPIFY PAYMENTS (USA) IN	GJPCARD0122035	2/4/2026	103012224	Fire-Operating Supplies	TAGS	506.00		
		752303920 TYLER TECHNOLOGIES	GJPCARD0122037	2/4/2026	103012334	Fire-Travel/Training/Seminars	CONFERENCE	1,249.00		
		473175020 CHICALL, LLC	GJPCARD0122043	2/4/2026	103012349	Fire-Services	SHIPPING	23.61		
		VEN001337 Menards	GJPCARD0122048	2/4/2026	103012472	Fire-Equip	DRILL BITS/SANDPAPER	16.01		
		VEN001337 Menards	GJPCARD0122051	2/4/2026	103012472	Fire-Equip	DRILL/PAINT/PIPING	280.72		
		202936165 AMAZON.COM, INC.	GJPCARD0122053	2/4/2026	103012334	Fire-Travel/Training/Seminars	RETURN	-125.00		
		VEN001820 SQUARE, INC.	GJPCARD0122054	2/4/2026	103012334	Fire-Travel/Training/Seminars	K.DAVIS CLASS	675.00		
		474423930 INVESTIGATIVE CONCEPTS	GJPCARD0122056	2/4/2026	103012334	Fire-Travel/Training/Seminars	K.DAVIS	360.50		
		042896127 STAPLES INC	GJPCARD0122058	2/4/2026	103012223	Fire-Office Supplies	SUPPLIES	271.76		
		202936165 AMAZON.COM, INC.	GJPCARD0122059	2/4/2026	103012224	Fire-Operating Supplies	PLAUD NOTE4	189.00		
		VEN001922 THE HOME DEPOT	GJPCARD0122060	2/4/2026	103012472	Fire-Equip	NEW ENG84	851.62		

**Purchase Card Register**

City of Westfield

2/4/2026 1:55 PM

Page 15 of 18

WESTFIELD\KGAGNON

Fund No.	Fund Name	Buy-From Vendor Name	Document No.	Posting Date	G/L Acct.	G/L Account Name	Description	Amount	Check No.	Check Date
103	Fire Operating									
	<b>Fire</b>									
	460627442	SAFER BUILDINGS	GJPCARD0122063	2/4/2026	103012334	Fire-Travel/Training/Seminars	BOOK	149.00		
	392528671	SPRING MILL ACE LLC	GJPCARD0122064	2/4/2026	103012472	Fire-Equip	NEW ENGINE 84	872.00		
	392528671	SPRING MILL ACE LLC	GJPCARD0122065	2/4/2026	103012472	Fire-Equip	RETURN	-874.27		
	392528671	SPRING MILL ACE LLC	GJPCARD0122066	2/4/2026	103012472	Fire-Equip	NEW ENGINE84	299.00		
	392528671	SPRING MILL ACE LLC	GJPCARD0122072	2/4/2026	103012472	Fire-Equip	NEW ENGINE84	399.00		
	202936165	AMAZON.COM, INC.	GJPCARD0122082	2/4/2026	103012224	Fire-Operating Supplies	KEY TAGS	147.90		
	202936165	AMAZON.COM, INC.	GJPCARD0122085	2/4/2026	103012223	Fire-Office Supplies	LAPTOP TOTE	34.99		
	VEN001333	MEIJER	GJPCARD0122086	2/4/2026	103012224	Fire-Operating Supplies	WATER	2.78		
	582671638	ALLS HAND FIRE EQUIPMENT	GJPCARD0122089	2/4/2026	103012472	Fire-Equip	TRT EQUIPMENT	99.94		
	820544687	AMAZON.COM, INC.	GJPCARD0122091	2/4/2026	103012347	Fire-Promotions	CANDY	14.84		
	202936165	AMAZON.COM, INC.	GJPCARD0122092	2/4/2026	103012224	Fire-Operating Supplies	GRILL BRUSH	74.95		
	824369995	EMS TRAINING SCHOOL LLC	GJPCARD0122093	2/4/2026	103012334	Fire-Travel/Training/Seminars	TUITION	795.00		
	473175020	CHICALL, LLC	GJPCARD0122094	2/4/2026	103012349	Fire-Services	SHIPPING	352.90		
	770467272	NETFLIX, INC.	GJPCARD0122108	2/4/2026	103012350	Fire-Subscriptions/Dues	NETFLIX	33.98		
	202936165	AMAZON.COM, INC.	GJPCARD0122109	2/4/2026	103012224	Fire-Operating Supplies	TOWELS, ETC	369.89		
	473175020	CHICALL, LLC	GJPCARD0122112	2/4/2026	103012349	Fire-Services	SHIPPING	109.81		
	VEN005978	Rescue Gear	GJPCARD0122114	2/4/2026	103012472	Fire-Equip	TRT EQUIPMENT	435.00		
	831960637	OPENAI OPCO, LLC	GJPCARD0122119	2/4/2026	103012350	Fire-Subscriptions/Dues	CHATGPT	200.00		
	VEN000946	IN BMV VEHICLE SER	GJPCARD0122121	2/4/2026	103012360	Fire-Vehicle Maint	REGISTRATION	15.00		
	VEN003173	AMAZON MKTPLACE	GJPCARD0122127	2/4/2026	103012224	Fire-Operating Supplies	AMAZON MKTPL	73.09		
	VEN001337	Menards	GJPCARD0122128	2/4/2026	103012334	Fire-Travel/Training/Seminars	MENARDS	6.09		
	VEN012843	FRAUD	GJPCARD0122129	2/4/2026	103012349	Fire-Services	INTERNATIONAL TRANS	0.12		
	VEN012843	FRAUD	GJPCARD0122130	2/4/2026	103012349	Fire-Services	FRAUD	24.49		
	VEN012843	FRAUD	GJPCARD0122131	2/4/2026	103012349	Fire-Services	FRAUD	0.24		
	VEN012843	FRAUD	GJPCARD0122132	2/4/2026	103012349	Fire-Services	FRAUD	12.18		
		<b>Subtotal for Fire</b>						<b>39,578.62</b>		
		<b>Subtotal for Fund 103 Fire Operating</b>						<b>39,578.62</b>		
201	Motor Vehicle Highway (MVH)									
	<b>Public Works</b>									
	933355248	PERSEUS PAYMENTS	GJPCARD0121651	2/4/2026	201013345	MVH-Equip Repair	#1991 PLOW REPAIR -	31.81		

**Purchase Card Register**

City of Westfield

2/4/2026 1:55 PM

Page 16 of 18

WESTFIELD\KGAGNON

Fund No.	Fund Name	Buy-From Vendor Name	Document No.	Posting Date	G/L Acct.	G/L Account Name	Description	Amount	Check No.	Check Date
201	Motor Vehicle Highway (MVH)									
	<b>Public Works</b>									
	440618012	O'REILLY AUTOMOTIVE STOR	GJPCARD0121720	2/4/2026	201013226	MVH-Vehicle Gas/ Supplies	DIESEL TREATMENT	89.94		
	440618012	O'REILLY AUTOMOTIVE STOR	GJPCARD0121796	2/4/2026	201013360	MVH-Vehicle Repair	OIL CHANGE ON	68.77		
	440618012	O'REILLY AUTOMOTIVE STOR	GJPCARD0121814	2/4/2026	201013360	MVH-Vehicle Repair	NEW BATTERY POOL	169.88		
	440618012	O'REILLY AUTOMOTIVE STOR	GJPCARD0121823	2/4/2026	201013345	MVH-Equip Repair	BATTERIES FOR #1991 -	278.36		
	202936165	AMAZON.COM, INC.	GJPCARD0121855	2/4/2026	201013345	MVH-Equip Repair	MUD FLAPS FOR DUMP	167.92		
	465707116	TRUCK COUNTRY OF INDIANA	GJPCARD0121860	2/4/2026	201013345	MVH-Equip Repair	REPAIRS FOR DUMP	36.10		
	440618012	O'REILLY AUTOMOTIVE STOR	GJPCARD0121866	2/4/2026	201013360	MVH-Vehicle Repair	OIL RESTOCK - INV.	150.99		
	202936165	AMAZON.COM, INC.	GJPCARD0121901	2/4/2026	201013345	MVH-Equip Repair	DUMP TRUCK PARTS	20.67		
	440618012	O'REILLY AUTOMOTIVE STOR	GJPCARD0121931	2/4/2026	201013360	MVH-Vehicle Repair	WIPER BLADES FOR	14.39		
	381909144	BELLE TIRE DISTRIBUTORS I	GJPCARD0121989	2/4/2026	201013345	MVH-Equip Repair	NEW TIRE SENSORS	782.15		
	440618012	O'REILLY AUTOMOTIVE STOR	GJPCARD0122007	2/4/2026	201013360	MVH-Vehicle Repair	O-RINGS, SHOP	136.42		
	920586309	PCW VI LLC	GJPCARD0122049	2/4/2026	201013360	MVH-Vehicle Repair	UNLIMITED CARWASH	599.90		
	440618012	O'REILLY AUTOMOTIVE STOR	GJPCARD0122069	2/4/2026	201013360	MVH-Vehicle Repair	OIL CHANGES #2461,	79.35		
	440618012	O'REILLY AUTOMOTIVE STOR	GJPCARD0122078	2/4/2026	201013360	MVH-Vehicle Repair	BATTERY #1691; OIL	297.90		
	202936165	AMAZON.COM, INC.	GJPCARD0122095	2/4/2026	201013345	MVH-Equip Repair	BINDERS FOR TRAILERS	685.60		
	133139732	TRACTOR SUPPLY CO	GJPCARD0122102	2/4/2026	201013345	MVH-Equip Repair	BRINE UNIT INSTALL	69.97		
		<b>Subtotal for Public Works</b>						<b>3,680.12</b>		
		<b>Subtotal for Fund 201 Motor Vehicle Highway (MVH)</b>						<b>3,680.12</b>		
202	Local Road and Street (LRS)									
	<b>Public Works</b>									
	VEN001337	Menards	GJPCARD0121746	2/4/2026	202013228	LRS-Signs and Posts	MAILBOX	187.97		
	202936165	AMAZON.COM, INC.	GJPCARD0121948	2/4/2026	202013228	LRS-Signs and Posts	RETURN CREDIT - SIGN	-23.49		
	844332073	WESTFIELD ACE, LLC	GJPCARD0121983	2/4/2026	202013228	LRS-Signs and Posts	SIGN DEPT HARDWARE	72.82		
	844332073	WESTFIELD ACE, LLC	GJPCARD0121993	2/4/2026	202013228	LRS-Signs and Posts	SIGN DEPT DRILL BITS	23.39		
	202936165	AMAZON.COM, INC.	GJPCARD0122111	2/4/2026	202013228	LRS-Signs and Posts	SIGN HARDWARE	23.49		
		<b>Subtotal for Public Works</b>						<b>284.18</b>		
		<b>Subtotal for Fund 202 Local Road and Street (LRS)</b>						<b>284.18</b>		

**Purchase Card Register**

City of Westfield

2/4/2026 1:55 PM

Page 17 of 18

WESTFIELD/KGAGNON

Fund No.	Fund Name	Buy-From Vendor Name	Document No.	Posting Date	G/L Acct.	G/L Account Name	Description	Amount	Check No.	Check Date
<b>206 Parks Programming/Events</b>										
<b>Parks</b>										
VEN001883	Target Corporation		GJPCARD0121636	2/4/2026	206005347	Parks Program-Promotions	WINTER MARKET	29.96		
201665019	FACEBOOK INC.		GJPCARD0121671	2/4/2026	206005347	Parks Program-Promotions	WINTER MARKET EVENT	61.00		
201665019	FACEBOOK INC.		GJPCARD0121684	2/4/2026	206005347	Parks Program-Promotions	WINTER MARKET EVENT	58.00		
201665019	FACEBOOK INC.		GJPCARD0121712	2/4/2026	206005347	Parks Program-Promotions	WINTER MARKET EVENT	52.00		
201665019	FACEBOOK INC.		GJPCARD0121713	2/4/2026	206005347	Parks Program-Promotions	WINTER MARKET EVENT	55.00		
201665019	FACEBOOK INC.		GJPCARD0121734	2/4/2026	206005347	Parks Program-Promotions	WINTER MARKET EVENT	50.00		
201665019	FACEBOOK INC.		GJPCARD0121777	2/4/2026	206005347	Parks Program-Promotions	WINTER MARKET EVENT	27.64		
262104214	WIX.COM LUXEMBOURG SARL		GJPCARD0121787	2/4/2026	206005347	Parks Program-Promotions	PHOTOGRAPHY FOR	300.00		
462967004	FINNER LLC		GJPCARD0121854	2/4/2026	206005347	Parks Program-Promotions	STAFF LUNCH	72.14		
831960637	OPENAI OPKO, LLC		GJPCARD0121974	2/4/2026	206005347	Parks Program-Promotions	CHAT GPT	60.00		
VEN000135	APPLE, INC. USA RETAIL		GJPCARD0121975	2/4/2026	206005347	Parks Program-Promotions	CAP CUT	192.59		
VEN011808	PIP Printing		GJPCARD0122031	2/4/2026	206005347	Parks Program-Promotions	WINTER MARKET	143.43		
VEN011808	PIP Printing		GJPCARD0122032	2/4/2026	206005347	Parks Program-Promotions	WINTER MARKET	502.09		
710938319	AMAZON.COM, INC.		GJPCARD0122115	2/4/2026	206005347	Parks Program-Promotions	AMAZON PRIME	14.99		
	<b>Subtotal for Parks</b>							<b>1,618.84</b>		
	<b>Subtotal for Fund 206 Parks Programming/Events</b>							<b>1,618.84</b>		
<b>239 Law Enforcement</b>										
<b>Police</b>										
813824965	TRANSACT CAMPUS PAYMENTS		GJPCARD0122079	2/4/2026	239002334	Law Enforce-Travel/Train	W OTTENWELLER	5,018.81		
	<b>Subtotal for Police</b>							<b>5,018.81</b>		
	<b>Subtotal for Fund 239 Law Enforcement</b>							<b>5,018.81</b>		
<b>Fund No. Fund Name</b>										
<b>255 F and E Programming/Events</b>										
<b>F and E</b>										
010571869	JH SPECIALTY		GJPCARD0121644	2/4/2026	255004347	F and E-Event Prog	EVENT SUPPLIES	200.57		
	<b>Subtotal for F and E</b>							<b>200.57</b>		
	<b>Subtotal for Fund 255 F and E Programming/Events</b>							<b>200.57</b>		

**Purchase Card Register**

City of Westfield

2/4/2026 1:55 PM

Page 18 of 18

WESTFIELD/KGAGNON

Fund No.	Fund Name	Buy-From Vendor No.	Buy-From Vendor Name	Document No.	Posting Date	G/L Acct.	G/L Account Name	Description	Amount	Check No.	Check Date
269	Training Facility Center										
	<b>Public Safety (Police and Fire)</b>										
		VEN000541	Department of Homeland Security	GJPCARD0122133	2/4/2026	269014350	Training Fac-Subscriptions	DEPT HOMELAND	220.00		
	<b>Subtotal for Public Safety (Police and Fire)</b>								<b>220.00</b>		
	<b>Subtotal for Fund 269 Training Facility Center</b>								<b>220.00</b>		
270	IT Surplus										
	<b>Informatics</b>										
		141659003	TOWER PRODUCTS INC	GJPCARD0121890	2/4/2026	270007451	IT Surplus-Computer Equip	GPEC ETHERNET REELS	1,472.61		
		770510487	PAYPAL	GJPCARD0122083	2/4/2026	270007451	IT Surplus-Computer Equip	GP AP EVENT STANDS	735.99		
	<b>Subtotal for Informatics</b>								<b>2,208.60</b>		
	<b>Subtotal for Fund 270 IT Surplus</b>								<b>2,208.60</b>		
	<b>Posted Invoices Total</b>								<b>136,385.01</b>		



## CITY OF WESTFIELD

# PROCLAMATION

### **HONORING WILL CHAMBLEY RECIPIENT OF THE CONGRESSIONAL AWARD GOLD MEDAL**

**WHEREAS:** the City of Westfield proudly recognizes exceptional young residents whose achievements exemplify leadership, service, and personal growth; and

**WHEREAS:** Westfield High School senior Will Chambley has earned the Congressional Award Gold Medal, the highest honor bestowed by the United States Congress for youth achievement and awarded to fewer than 500 students nationwide each year; and

**WHEREAS:** to earn this distinction, Will completed 400 hours of voluntary public service, over 200 hours of personal development, over 200 hours of physical fitness, and fulfilled the Award's expedition and exploration requirement through a planned and executed trip to Puerto Rico; and

**WHEREAS:** Will has demonstrated extraordinary commitment to his community through volunteer work with Westfield Welcome, Indy Great Pyrenees Rescue, Westfield Aquatics, local libraries, Westfield High School, and Indiana Swimming; and

**WHEREAS:** in addition to his service, Will is a dedicated student-athlete known for academic excellence, strong analytical skills, and leadership, earning membership in multiple honor societies and recognition as an Indiana CPA Society Scholar; and

**WHEREAS:** Will's accomplishments reflect the mission of the Congressional Award and serve as an inspiration to young people throughout Westfield; and

**NOW, THEREFORE:** I, Mayor Scott Willis, on behalf of the City of Westfield, do hereby recognize and honor Will Chambley for earning the Congressional Award Gold Medal and for his outstanding contributions to our community.

**IN WITNESS WHEREOF,** this proclamation is presented on the 12th day of January, 2026, with the congratulations and pride of the entire Westfield community.

(City Seal Here)

---

**Scott Willis, Mayor  
City of Westfield**



CITY OF  
**Westfield**  
INDIANA

Westfield Mayor's Youth Council  
February 9, 2026

# Examples



## Locations Considered

- Location 1: Asa Bales Park
- Location 2: Grand Junction Plaza
- Location 3: Simon Moon Park
- Location 4: Freedom Trail
- Location 5: Quaker Park



# Location Selected

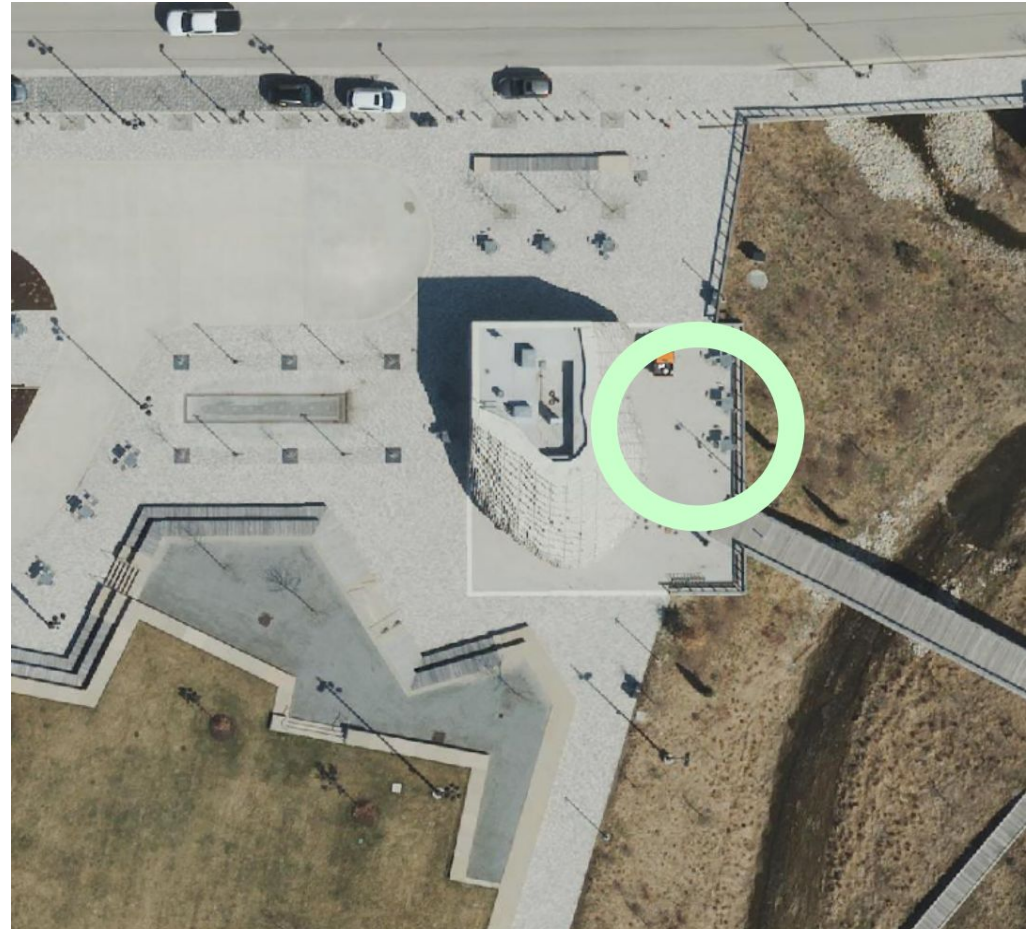
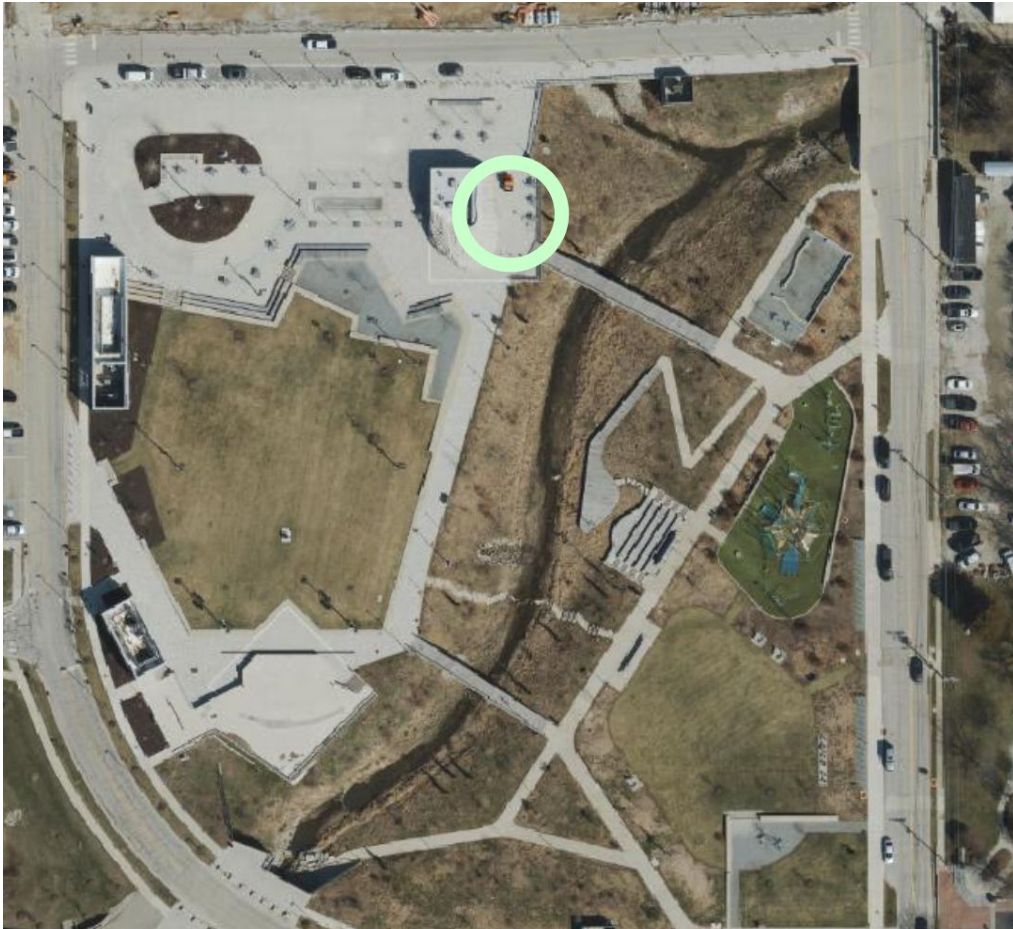

# Table Design

Key elements:

- Cost
- Solar Array
- Structure
- Charging
- Table & Seating



# Dimensions and Details

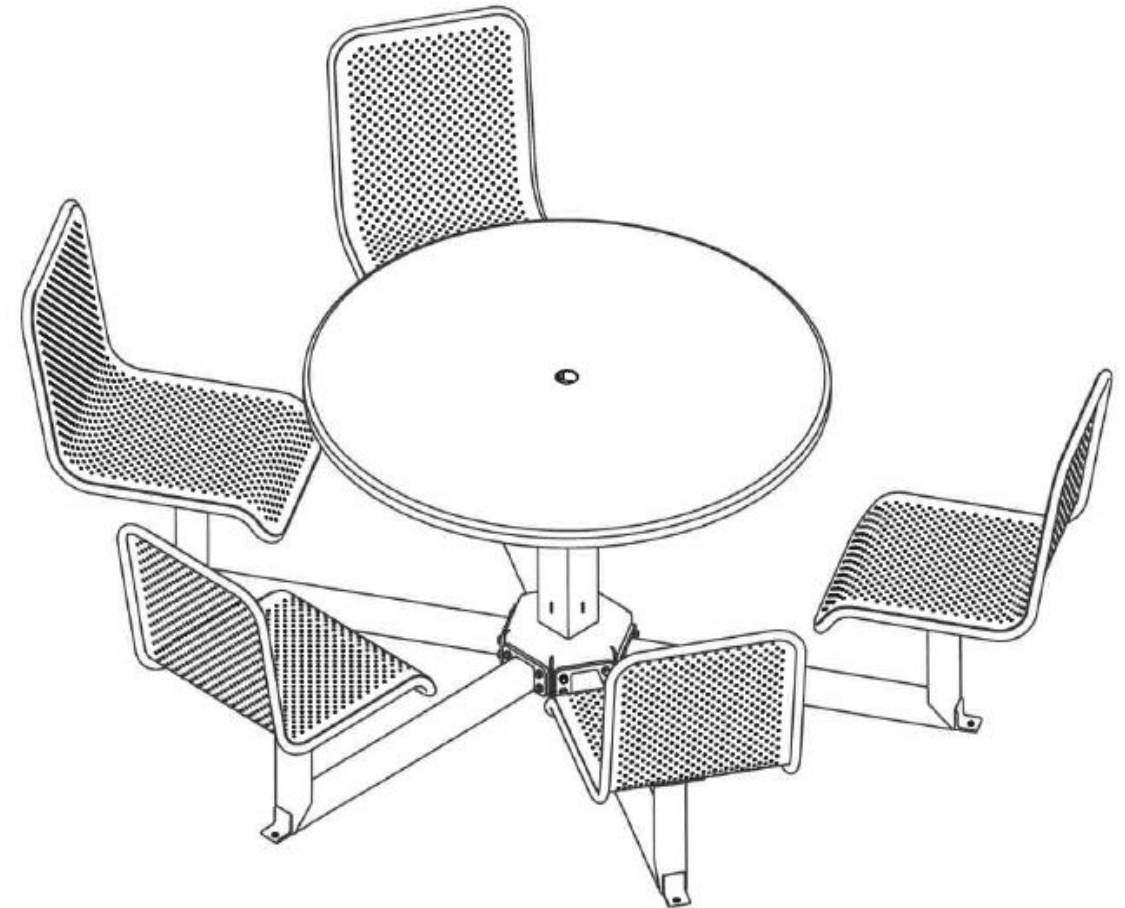
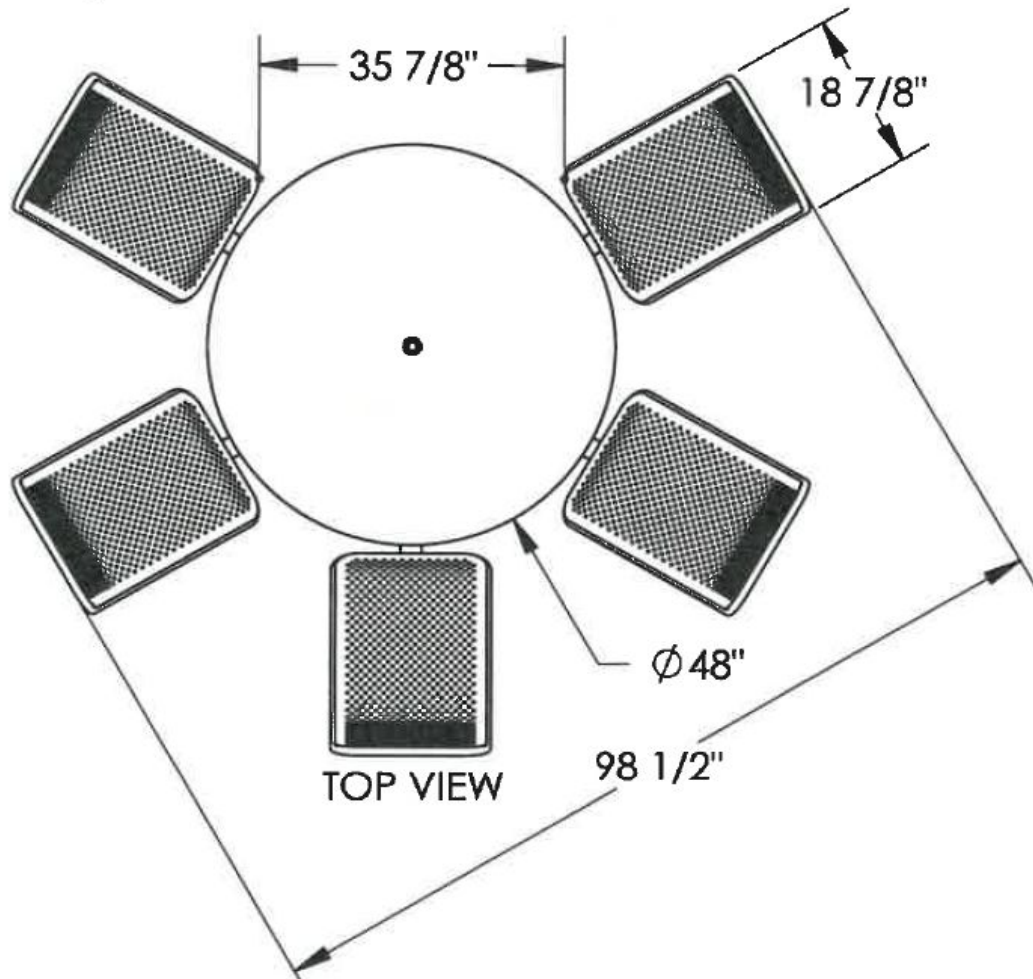

# Benefits



- Outdoor Studying
- Park Usage
- Sustainability

## Form of Recognition



Signage will be posted on the donor wall at Grand Junction Plaza (Building R)

- 24” x 24” plaque that highlights the WMYC and its members
- Zinc magnesium

# Longevity



## Structure

- Concrete/galvanized-steel: 20-70+ years

## Power

- Solar panels: 20 to 30 years
- Battery pack: 5 to 20+ years

# Upkeep and Maintenance

## Peak Season (Spring)

- Solar panels
- Electrical components
- Protective sealant

## Routine Upkeep (Summer)

- Solar panels
- Electrical components
- Overheating

# Upkeep and Maintenance

## Low Use Season (Fall)

- Solar panels
- Protectant
- Vegetation

## Low Use Season (Winter)

- Electrical components
- Ice Damage
- Snow

# Community Involvement

- Documenting the process via photography and video
- Updating the public with semi-frequent updates via the City of Westfield's social media channels and/or e-newsletter updates
  - Updates will be drafted by the Youth Council
- Ribbon cutting open to city staff and the community
  - Date to be announced

# Budget

The WMYC has been granted **\$15,000** for this project. The funds will be used as follows:

## Equipment

- Arbor Solar Carousel Table: \$10,800
- Plaque: \$2,036

## Shipping and Fees

- Steel surcharge: \$126
- Shipping and handling: \$1,695

## Installation

- In-kind donation from the Westfield Parks & Recreation Department: \$0

**Total: \$14,657**

## Parks Department Match

- Westfield Parks & Recreation Department to match WMYC's table donation via a non-reverting fund
- WMYC will pay for shipping for both tables

The background features a dark blue field with a repeating pattern of lighter blue, semi-transparent diamond shapes. On the left side, there are several thick, bright green diagonal lines that intersect to form a stylized, abstract graphic. The text 'Thank you!' is positioned in the upper right quadrant in a clean, white, sans-serif font.

Thank you!

**ORDINANCE 26-01**

**AN ORDINANCE TO AMEND PROVISIONS  
IN THE WESTFIELD-WASHINGTON TOWNSHIP  
UNIFIED DEVELOPMENT ORDINANCE**

**WHEREAS**, the City of Westfield, (the “City”) is a duly formed municipal corporation within the State of Indiana, governed by its duly elected Mayor and Common Council (the “Council”); and,

**WHEREAS**, it is the duty and the responsibility of the City to administer the Westfield-Washington Township Unified Development Ordinance (the “UDO”) throughout the City and Washington Township, Indiana as identified through the adoption of a Joinder Agreement; and,

**WHEREAS**, from time to time it is necessary to amend and revise the UDO, and pursuant to I.C. § 36-7-4-602 and I.C. § 36-7-4-701, the City is authorized to amend the UDO; and

**WHEREAS**, on \_\_\_\_\_, 2026, the Westfield-Washington Township Advisory Plan Commission forwarded Petition No. 2601-ZOA-01 to the Council with a favorable recommendation in accordance with Indiana Code § 36-7-4-607; and

**NOW, THEREFORE, BE IT ORDAINED** by the Common Council of the City of Westfield, Hamilton County, Indiana, meeting in regular session, that the following provisions of the Unified Development Ordinance are amended as follows:

**Section 1.**     **Article 6.9(D)(4) Lighting Standards; Prohibitions** shall be removed.

**Section 2.**     **Article 6.9(G) Lighting Standards; Sign Lighting** shall be replaced as follows: Illumination of Signs shall be regulated by Article 6.17 Sign Standards.

**Section 3.**     **Article 6.17 Sign Standards** shall be replaced by **Exhibit A** of this Ordinance.

**Section 4.**     **Article 10.11 Processes & Permits; Sign Permits** shall be amended as follows:  
A. **Article 10.11(D) Signs Within a Floodplain:** Floodplain review shall be required for new Signs that involve significant filling, grading, or excavation within a Floodway, or that have the potential to affect flood flows.

**Section 5.**     **Article 12.1 Definitions** shall be amended as follows:

- A. Add new definition to read as follows:
1. **Awning:** A roof-like Structure, typically made of nonrigid materials, mounted above a storefront, window or door that projects from the Building wall and provides shelter from sun and rain.
  2. **Canopy:** A permanent shelter composed of rigid materials that is supported partially or entirely from the exterior wall of a Building.

3. **Canopy, Freestanding:** A Structure having a roof supported by columns that is not supported by or otherwise integrally attached to the exterior wall of a Building.
4. **Commercial Message:** Any Sign, wording, or logo that directly names or advertises a specific business, proprietary product or service, or other commercial activity. A message intended to direct attention to a political candidate or election, or a political, social, religious, or community issue, idea, or viewpoint, and not intended to encourage a commercial transaction shall not be deemed a Commercial Message.
5. **District:** See *District, Zoning*.
6. **District, Agricultural:** Shall mean and refer to individually, or collectively, the Zoning Districts listed under “Agricultural Districts” in *Article 4.1 Establishment of Districts*.
7. **District, Nonresidential:** Shall mean and refer to individually, or collectively, an Agricultural District, Business District, and/or Industrial District.
8. **Drive-through:** An accessory feature of an establishment including service units and stacking spaces that permits customers to receive services or obtain goods while remaining in or on a motor vehicle.
9. **Drive-through Lane:** The portion of a Drive-through accommodating a single line of vehicles. A Drive-through can contain multiple Drive-through Lanes.
10. **Election Season:** A period of time beginning sixty (60) days before and six (6) days after a general election, municipal election, primary election, school district election, or special election.
11. **Fascia:** Any broad, flat, horizontal surface, as the outer edge of a roof or Canopy.
12. **Mural:** A hand-formed image or design that is applied, affixed, or painted directly on a building or structure. A mural shall not include digitally printed vinyl, electronic display panels, or other mechanically produced images.
13. **Sign, Banner:** A Temporary Sign constructed of nonrigid material with or without a support frame.
14. **Sign, Blade:** A Sign extending from and oriented perpendicularly to the face or corner of a Building. Blade Signs are generally taller than they are wide with vertically oriented text and graphic elements.
15. **Sign, Canopy:** A Sign attached to, located on, or extending above the top of a Canopy.
16. **Sign, Drive-through:** A one-sided freestanding sign adjacent to and oriented towards a Drive-through Lane.

17. **Sign, Externally Illuminated:** A Sign illuminated by an independent light source aimed at the Sign for the purpose of illumination.
18. **Sign Face:** The area of a Sign on which the Sign Copy is placed or that draws attention to the sign.
19. **Sign, Freestanding Canopy:** A Sign located entirely on the Fascia of a Freestanding Canopy.
20. **Sign, Ground:** Any Sign whose primary support is permanently fixed within the ground. Ground Signs may include Monument Signs, Post Signs, and Pole Signs.
21. **Sign, Incidental:** A permanent Sign designed and located to be read by people within a specific site or development and generally not legible from external properties or rights-of-way. Examples include, but are not limited to, Signs indicating hours of operation, Signs on vending machines, ATMs, gas pumps, or retail kiosks, exterior display boards, tenant directory Signs, campus directional Signs, and other Signs intended to be read at close proximity. The Director shall determine whether a Sign is an Incidental Sign based on the visibility of the sign from the lot line or right-of-way, the number of signs in close proximity of each other, and/or the presence of a Commercial Message.
22. **Sign, Internally Illuminated:** A Sign illuminated by a light source that is contained within or concealed by the Sign structure, and Signs that are intrinsically formed by a light source; including but not limited to front-lit, halo-lit, reverse-channel letter, neon, and marquee bulb signs.
23. **Sign, On-Premises:** A Sign directing attention to a business, product, service, entertainment, or any other activity that is offered, sold, or conducted upon the Lot where the Sign is displayed.
24. **Sign, Post:** A Sign which is permanently fixed to the ground and supported by 1 (one) or more poles, posts, pillars, braces, or bases so that the bottom-most edge of the Sign face is less than six (6) feet above grade.
25. **Sign, Temporary:** A nonpermanent Sign intended for a limited time of display.
26. **Sign, Temporary Freestanding:** A freestanding Sign constructed of rigid materials intended to be displayed for a designated period. For the purposes of this definition, rigid materials shall include wood, aluminum, corrugated plastic, PVC board, and similar materials.
27. **Sign, Yard:** A Freestanding Temporary Sign constructed of rigid, lightweight, and/or non-durable materials.

B. Modify the following definitions as follows:

## Unified Development Ordinance Amendment

1. **District, Residential:** Shall mean and refer to individually, or collectively, ~~an Agricultural District, a~~ Single-family District ~~and/or~~ Multi-family District.
2. **Nonresidential Center:** A building or combination of buildings containing two (2) or more tenants, stores, service establishments, offices or other permitted Uses which are planned, platted, organized, or managed to function as a unified whole and shares one (1) or more of the following: (1) vehicular access; (2) Parking Areas; (3) signage; (4) landscaping; or (5) design theme; and/or is platted as part of a campus, Subdivision or coordinated shopping center, which may include Outlots for lease or for sale.
3. **Sign:** Any name, identification, description, display, or illustration which is affixed to, painted on, or is represented directly or indirectly upon a Building, Structure, or Premises, and which conveys a Commercial Message. ~~display or device placed on a property in any fashion which is designed, intended, or used to convey any identification, message or information other than an address number.~~
4. **Sign, Awning:** Any ~~advertising or display~~ Sign located on any ~~nonrigid material that extends from the exterior wall of a building and is supported by or attached to a frame~~ an Awning.
5. **Sign, Center:** ~~Advertising~~ A Sign used to identify a Nonresidential Center, ~~which may include individual tenant advertising.~~
6. **Sign, Electronic:** A Sign or Sign component with a fixed or changeable display composed of a series of lights, including ~~but not limited to~~ light emitting diodes (LED), fiber optics, or other illumination devices within an electronic display panel that may be changed through electronic or mechanical means.
7. **Sign, Monument (or Ground):** A Sign which is permanently fixed to the ground by a structural base or other solid structural feature and constructed of a permanent material, such as brick or manufactured stone.
8. **Sign, Pole:** A Sign which is permanently fixed to the ground and supported by one (1) or more poles, posts, or braces upon the ground, in excess of six (6) feet in height, not attached to or supported by any building, so that the bottom-most edge of the Sign face is greater than six feet (6') above grade.
9. **Sign, Projecting:** A Sign ~~attached to a building or wall and extending laterally more than eighteen (18) inches from the face of a wall~~ mounted perpendicular to and extending away from a building face or wall. Projecting Signs are generally wider than they are tall with horizontally oriented text and graphic elements. The Sign board may be attached directly to a Building face or suspended from a bracket or frame.

10. **Sign, Sandwich Board:** A portable, On-Premises, Sign for display in front of a Building business for the specific Use of advertising that business.
11. **Sign, Window:** A Sign that is applied to, ~~or attached to,~~ or painted upon the exterior or interior of a window or located in such a manner within a ~~Building~~ that it is intentionally visible from the exterior of the ~~Building~~ through a window, but ~~excludes~~ shall not include merchandise window displays, seasonal window paintings not containing a Commercial Message, or Murals covering a window.

C. Remove the following definitions as follows:

1. ~~**Sign, Acreage For Sale:** A Sign announcing the sale, rental, or lease of land.~~
2. ~~**Sign, Direction:** A Sign intending to direct the safe flow of vehicular and pedestrian traffic and includes "enter," "exit," and "arrow" Signs.~~
3. ~~**Sign, Election:** A type of Temporary Sign defined in I.C. 36-1-3-11.~~
4. ~~**Sign, Construction:** A Sign directing attention to construction upon a property where the Sign is displayed, and bearing the name, address, or other identifier of the contractor, subcontractor, architect and/or development team.~~
5. ~~**Sign, Gas Price:** A Sign displaying only the price of gasoline.~~
6. ~~**Sign, Home Construction or Home Remodeling Sign:** A Temporary Sign used to advertise business entities conducting remodeling or construction work activities on a given parcel during the period that remodeling or construction activities are taking place on the given parcel.~~
7. ~~**Sign, Illuminated:** A Sign which has characters, letters, figures, designs, or outline illuminated by electric lights or luminous tubes as a part of the Sign property, or which is illuminated by reflectors.~~
8. ~~**Sign, Interior Circulation:** A Sign intending to direct the safe flow of vehicular and pedestrian traffic and includes "enter," "exit," and "arrow" Signs. Interior Circulation Signs are not commercial way-finding Signs.~~
9. ~~**Sign, Nonresidential Real Estate:** A Sign announcing the sale, rental, or lease of nonresidential property.~~
10. ~~**Sign, Nonresidential Special Event:** A Temporary Sign for a nonresidential entity, including businesses, charitable organizations, or not-for-profit corporations, which advertises grand openings, customer appreciation events, public gatherings, and other similar events as determined by the Director.~~
11. ~~**Sign, Open House Directional:** A Temporary Sign used to advertise an open house and direct traffic to the house for sale.~~

- ~~12. **Sign, Pylon:** A Sign constructed upon the ground on a solid foundation with the Sign surface resting directly on top of such foundation and intended to identify multiple businesses.~~
- ~~13. **Sign, Real Estate:** A Sign announcing the sale, rental, or lease of real property.~~
- ~~14. **Sign, Residential Event:** A Temporary Sign utilized to advertise residential garage sales, yard sales, individual residential events, subdivision or neighborhood events and other similar events as determined by the Director.~~
- ~~15. **Sign, Residential Real Estate:** A Sign announcing the sale, rental, or lease of residential property.~~
- ~~16. **Sign, Special Event:** A Sign advertising or announcing a special community wide event or activity conducted or sponsored by or on behalf of the City, Westfield Washington Schools, a charitable organization or a not for profit corporation. A special community wide event or activity is one that occurs not more than twice in any twelve (12) month period and seeks to attract donations, participants or customers throughout the City.~~
- ~~17. **Sign, Time and Temperature:** A Sign displaying only the current time and/or outdoor temperature.~~

**Section 8.**

This Ordinance shall be in full force and effect in accordance with Indiana law, upon the passage of any applicable waiting periods, all as provided by the laws of the State of Indiana. All ordinances or parts thereof that are in conflict herewith are hereby ordered repealed. All acts undertaken to in creation of this Ordinance are hereby ratified.

**[The remainder of this page intentionally left blank.]**

ALL OF WHICH IS ORDAINED THIS \_\_\_\_\_ DAY OF \_\_\_\_\_, 2026.  
WESTFIELD CITY COUNCIL

**Voting For**

**Voting Against**

**Abstain**

\_\_\_\_\_  
Jon Dartt

\_\_\_\_\_  
Jon Dartt

\_\_\_\_\_  
Jon Dartt

\_\_\_\_\_  
Victor McCarty

\_\_\_\_\_  
Victor McCarty

\_\_\_\_\_  
Victor McCarty

\_\_\_\_\_  
Joe Duepner

\_\_\_\_\_  
Joe Duepner

\_\_\_\_\_  
Joe Duepner

\_\_\_\_\_  
Patrick Tamm

\_\_\_\_\_  
Patrick Tamm

\_\_\_\_\_  
Patrick Tamm

\_\_\_\_\_  
Noah Herron

\_\_\_\_\_  
Noah Herron

\_\_\_\_\_  
Noah Herron

\_\_\_\_\_  
Kurt Wanninger

\_\_\_\_\_  
Kurt Wanninger

\_\_\_\_\_  
Kurt Wanninger

\_\_\_\_\_  
Chad Huff

\_\_\_\_\_  
Chad Huff

\_\_\_\_\_  
Chad Huff

ATTEST:

\_\_\_\_\_  
Marla Ailor, Clerk Treasurer

I hereby certify that ORDINANCE 26-01 was delivered to the Mayor of Westfield

on the \_\_\_\_\_ day of \_\_\_\_\_, 2026, at \_\_\_\_\_ m.

\_\_\_\_\_  
Marla Ailor, Clerk-Treasurer

I hereby APPROVE ORDINANCE 26-01

I hereby VETO ORDINANCE 26-01

this \_\_\_\_\_ day of \_\_\_\_\_, 2026.

this \_\_\_\_\_ day of \_\_\_\_\_, 2026.

\_\_\_\_\_  
Scott Willis, Mayor

\_\_\_\_\_  
Scott Willis, Mayor

This document prepared by:

Lauren Gillingham-Teague, AICP

Senior Planner

City of Westfield, Community Development Department

2728 East 171<sup>st</sup> Street, Westfield, Indiana 46074 | (317) 804-3175

I affirm, under the penalties for perjury, that I have taken reasonable care to redact each Social Security Number in this document, unless required by law: Lauren Gillingham-Teague

**EXHIBIT A****6.17 Sign Standards**

- A. **Purpose and Intent:** The community wishes to establish Sign regulations for the design, placement, and maintenance of Signs which provide a reasonable and impartial means to permit communication, protect the public health, safety, and general welfare, minimize hazards to pedestrians and motorists along Streets and at intersections, enhance the aesthetic environment of the community, safeguard Property values, minimize possible adverse effects of Signs on nearby Property, protect public and private investment in Buildings and open space, and implement relevant provisions of the Comprehensive Plan as updated. The community wishes to balance expressive rights with the rights of the public to have uncluttered, safe, and attractive public Rights-of-way and sightlines. The responsible regulation of Signs will foster business opportunities and improve the quality of life in the community.
- B. **Applicability:** This Article shall apply to all Signs in all Zoning Districts in the Jurisdiction of the Plan Commission, including but not limited to changes in Sign Copy. However, the owner of any Sign that is otherwise allowed by this Ordinance may substitute noncommercial copy in place of any other commercial or noncommercial copy without the issuance of a permit.
- C. **Permits:** A Sign permit shall be required for all Signs unless otherwise exempted herein. The Director shall have the authority to review and decide upon Sign permit applications. See *Article 10.11 Sign Permits*. If the proposed Sign plan complies with the requirements of this Ordinance, then a Sign permit shall be issued within twelve (12) business days of receipt of a complete Application.
- D. **Sign Calculation Standards:**
1. **Sign Area:** Sign Area shall be computed as the smallest continuous perimeter enclosing the extreme limits of the Sign Copy, including all background area figures and letters. The perimeter shall not include any structural elements lying outside the limits of the Sign which are not part of the information, visual attraction, or symbolism of the Sign.

**FIGURE 6.17(A): SIGN AREA**

2. Sign Height: Sign Height shall be measured from the finished grade of the ground immediately beneath the Sign to the highest point of the Sign or Sign Structure. If the Sign is located on an artificial earthen berm, the Sign Height is measured from the highest point of the Sign to the base of the berm.
3. Sign Area Allocation: For the purposes of calculating Sign Area Allocation, the Building Façade shall include canopies, marquees, and other permanent building projections, but shall not include Awnings. Unless otherwise stated, the Sign Area Allocation shall be divided between all permitted Signs, including legally established nonconforming Signs.
4. Rights-of-way: For the purposes of this Article, the term “public Right-of-way” shall include public Streets, Private Streets, and circulation drives internal to Nonresidential Centers, but shall not include public paths or trails.
5. Absolute Minimum & Maximum Sign Area: In no instance shall a permitted nonresidential Use or in-line tenant be allocated less than twenty-five (25) square feet of Sign Area, nor shall any permitted nonresidential Use or tenant be permitted to display more than five hundred (500) square feet of Sign Area.

E. **Prohibitions**: The following shall be prohibited:

1. Signs or Sign Structures similar in coloring, shape, function, or location; or which resemble, conflict with, or may be confused with any approved traffic-control Sign or device.
2. Signs that create a safety hazard for vehicles or pedestrians, as determined by the Department of Public Works.
3. Signs placed in any Right-of-way, except publicly owned traffic-control and transit Signs, informational, identification, directional Signs, and temporary Signs, as regulated by this Article.
4. Pole Signs.
5. Off-premises Signs; except as otherwise permitted by this Article.
6. Display of ribbons, streamers, spinners, feather flags, balloons, or inflatable Signs.
7. Signs that project into the Right-of-way; except for Projecting Signs and Blade Signs as otherwise permitted by this Article.
8. Signs mounted on a roof or that extend above an eave or parapet of a Building Façade; except as otherwise permitted by this Article.
9. Signs that revolve, flash, blink, swing or appear to move.
10. Signs affixed to trees, fence posts, utility poles or other support Structures.
11. Signs affixed to Accessory Structures.
12. Signs placed on a vehicle, trailer, movable waste container, or temporary storage container which is then parked or positioned for the primary purpose of displaying the Sign.
13. Temporary Signs with Electronic Sign or manual changeable copy components.

**F. Sign Installation and Maintenance:**

1. Maintenance and Repair:
  - a. All Signs and Sign Structures shall be kept and maintained in a good state of repair and in a safe condition at all times. Maintenance and repair shall include, but not be limited to:
    - i. The replacement of defective parts.
    - ii. The replacement of missing or damaged Sign panels, supports or other components and parts.
    - iii. Cleaning Sign and Sign structure components.
    - iv. Repainting Sign and Sign structure components.
  - b. A Sign or Sign Structure may be taken down or removed for up thirty (30) days for the purposes of maintenance and repair.
  - c. Signs in disrepair for a period exceeding six (6) consecutive months shall be in violation of this Ordinance and subject to enforcement.
  - d. See *Article 9.6 Nonconforming Signs* for additional standards.
2. Abandoned Signs: The following shall apply to permanent Signs and Sign Structures:
  - a. Sign Copy shall be removed by the Property Owner or lessee of a site upon which the Sign is located within three (3) months of the associated business or service ceasing operations on the premises.
  - b. Legal Conforming Sign Structures with copy removed may remain for up to twenty-four (24) months provided that the Sign structure is maintained pursuant to this Article.
  - c. Legal Nonconforming Sign Structures with copy removed may remain for up to six (6) months provided that the Sign structure is maintained pursuant to this Article. After which time, the Sign shall be considered abandoned and be subject to removal in accordance with *Article 9.6 Nonconforming Signs*.
  - d. For purposes of this section, “operation” refers to the activity occurring on the Property and not to the mere generation of income for the Property Owner, or the intentions of the Property Owner or any tenant or sub-tenant.
3. Sign Panel Replacement: The replacement of tenant panels within a Ground Sign or Wall Sign shall not require a Sign permit.
4. Setbacks: All Signs shall be a minimum distance of five (5) feet from all Property Lines. Internally-Illuminated Signs for Nonresidential Uses shall be setback a minimum distance of twenty-five (25) feet from any Residential Use or District.
5. Lines of Sight: All Signs shall comply with *Article 6.19 Vision Clearance Standards*.

**G. Sign Lighting:** Permanent Signs may be illuminated as follows. Otherwise, illumination standards for each Sign type shall be as outlined in Section J of this Article.

1. General Standards:
  - a. All external Light Fixtures used to illuminate an outdoor Sign shall be Fully Shielded and oriented to direct all light output towards the Sign surface and away from adjacent lots and Rights-of-way.

- b. Internally-Illuminated Signs for Nonresidential Uses shall be setback a minimum distance of twenty-five (25) feet from any Residential Use or District.
  - c. Lighting shall not flash, blink, or otherwise give the appearance of movement.
  - d. Gaseous or LED neon tubing may be used to illuminate, outline, or form individual letters, symbols, or stylistic elements of a Sign only if integrated with a non-illuminated background or support frame.
  - e. The illumination of, or light produced by, any Sign shall not increase nighttime ambient lighting conditions by more than 0.3 Foot-candles as measured at a distance recommended by the International Sign Association relative to the Sign's size. Ambient light monitors and automatic level controls shall be used to automatically reduce the brightness of the Sign at night and under cloudy or darkened conditions.
2. Agricultural and Residential Districts: Ground Signs in Agricultural and Residential Districts shall not be Internally Illuminated.
- H. **Electronic Signs**: Signs with electronic display components shall comply with the following:
- 1. Except as otherwise permitted by this article, Electronic Sign components shall be limited to Monument Signs for Nonresidential uses.
  - 2. The entire electronic display area of an Electronic Sign component shall count toward the permitted Sign Area, as applicable to the type of Sign (e.g., Monument Sign) and as permitted in this Article.
  - 3. The maximum height of any letter, number or character shall be twenty (20) inches.
  - 4. The combined area of all Electronic Sign components shall not exceed fifty percent (50%) of the Sign Area of the Sign on which it is located or sixty (60) square feet, whichever is less.
  - 5. The effects or use of moving, flashing, blinking, animation, scrolling, twirling or other similar effects (including video) are prohibited.
  - 6. Any image or message shall have a static display for a minimum duration of fifteen (15) seconds.
  - 7. Changes of image shall be instantaneous as seen by the human eye and shall not use fading, rolling, window shading, dissolving or similar effects as part of the change.
  - 8. Signs with Electronic Sign components are considered to be Internally Illuminated.
- I. **Murals**: Art Murals in Nonresidential and Multi-family Districts shall comply with the following:
- 1. A permit is not required to erect, maintain, alter, or enlarge an art Mural that contains no Commercial Message.
  - 2. Acknowledgement Panel: Murals may include an acknowledgement panel with the names or logos of art sponsors. This panel shall adjoin the bottom edge of the mural and shall not exceed two (2) square feet in area. Such acknowledgement panel shall not be classified as a Commercial Message.
  - 3. Murals with a Commercial Message:

- a. Any Mural containing a direct Commercial Message, as defined by this Ordinance, shall be considered a Wall Sign and deduct from a Building's Sign Area Allocation.
- b. Sign Area: For the purposes of calculating Sign Area, the Sign Area shall be limited to the extent of the Commercial Message and shall not include any noncommercial illustrations or designs that may be present in the Mural.

J. **Permanent Signs Requiring a Sign Permit**: The following Signs shall require a Sign Permit:

1. Wall Signs: All Wall Signs shall comply with the following unless otherwise stated in this Article:
  - a. Location: Shall be located within the Sign Plane and shall not substantially obscure any architectural enhancements or features (e.g., brick detailing, changes in materials) of the Building Façade.
  - b. Sign Plane: Shall not exceed fifty percent (50%) of the Sign Plane.
  - c. Maximum Sign Area: Under no circumstances may a single Wall Sign exceed three hundred (300) square feet.
  - d. Illumination: May be Internally or Externally Illuminated.
  - e. Exposed raceways shall be finished to match the background wall or be integrated into the overall design of the Sign.

FIGURE 6.17(B): WALL SIGN

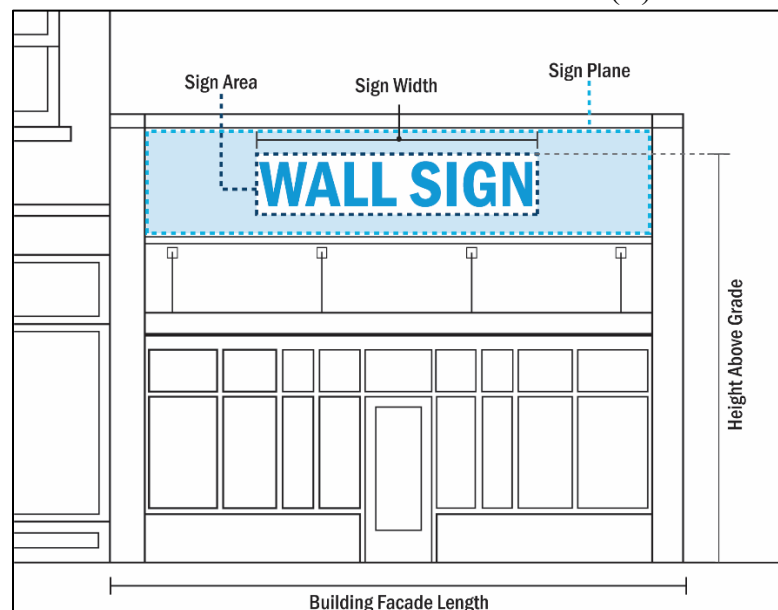

2. Projecting Signs: All Projecting Signs shall comply with the following unless otherwise stated in this Article:
  - a. Location: Projecting Signs shall be generally located on the ground floor of a Building and within eight (8) feet of a public entrance.

- b. Clearance: Sign shall maintain a minimum vertical clearance of eight (8) feet above grade when measured from the bottom of the Sign, and a minimum horizontal clearance of two (2) feet from the back of a curb.
- c. Maximum Height Above Grade: The top of the Sign Board shall not exceed the bottom of the second story windows or sixteen (16) feet above grade, whichever is less.
- d. Maximum Sign Width: Shall not extend more than five (5) feet from the face of the Building.
- e. Maximum Sign Area: Unless otherwise stated in this Article, a Projecting Sign shall not exceed twelve (12) square feet.
- f. A Projecting Sign may extend from a Building corner when adjoining an intersection. The Sign Area shall subtract from the Sign Area Allocation of both Facades.
- g. Illumination: The Sign may be Externally Illuminated by a fixture located on top of or above the sign structure. Individual letters, symbols, and stylistic elements of a Sign may be Internally Illuminated if integrated with a non-illuminated background or support frame. Internally illuminated light boxes or cabinet signs are prohibited.

FIGURE 6.17(C): PROJECTING SIGN

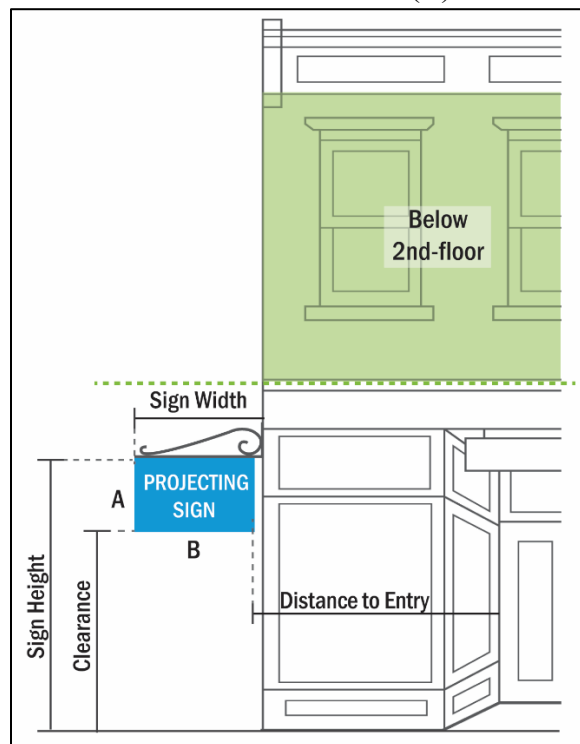

3. Blade Signs: All Blade Signs shall comply with the following unless otherwise stated in this Article:
  - a. Location: Blade Signs shall be located above the ground floor of a Building, but shall not extend above the roofline.
  - b. Quantity: Not to exceed one (1) per Building.

- c. Minimum Height Above Grade: The bottom of the Sign shall be located at or above the bottom of the second story windows or sixteen (16) feet above grade, whichever is greater.
- d. Maximum Sign Height: The height of the Sign shall not exceed sixty percent (60%) of the total height of the Building Façade above the ground floor when measured from the second-story finished floor elevation to the eaves of the roofline or the bottom of the parapet, not to exceed twenty-five (25) feet.
- e. Maximum Sign Width: Shall may not extend more than five (5) feet from the face of the Building.
- f. Maximum Sign Area: Seventy-five (75) square feet.
- g. Must be located at least twenty-five (25) feet from any other Blade Sign.
- h. A Blade Sign may be located on a Building corner when adjoining an intersection; in such case the Sign Area shall subtract from the Sign Area Allocation of both Facades.
- i. Illumination: Individual letters, symbols, and stylistic elements of a Sign may be Internally Illuminated if integrated with a non-illuminated background or support frame. Internally illuminated light boxes or cabinet signs are prohibited.

FIGURE 6.17(D): BLADE SIGN

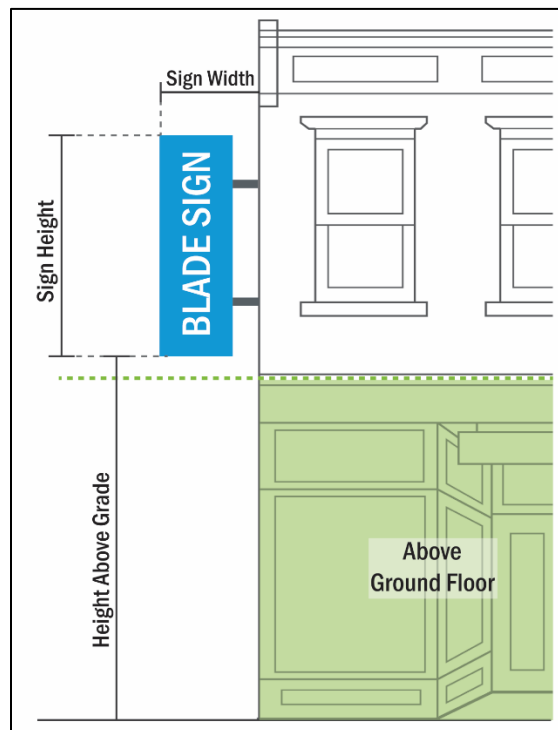

4. Under Canopy, Canopy, and Freestanding Canopy Signs: Signs attached to Canopies shall comply with the following unless otherwise stated in this Article:
  - a. Under Canopy Signs:
    - i. Location: Shall be attached to and located entirely under a canopy or roof overhang.

- ii. Quantity: Shall not exceed one (1) per public entrance per tenant.
  - iii. Clearance: Shall maintain a minimum vertical clearance of eight (8) feet when measured from the bottom of the sign.
  - iv. Maximum Sign Area: Shall not exceed two and a half (2.5) square feet.
  - v. Under Canopy Signs shall not deduct from a tenant’s Sign Area allotment.
  - vi. Illumination: Shall not be separately illuminated.
- b. Canopy Signs:
- i. Location: May be located on, above, or below the Canopy Fascia, but may not extend above a roofline or eave.
  - ii. Quantity: Shall not exceed one (1) per public entrance.
  - iii. Maximum Sign Width:
    - (a) Ninety percent (90%) of the tenant’s Canopy length if fourteen (14) feet or less.
    - (b) Seventy percent (70%) of the tenant’s Canopy length if greater than fourteen (14) feet.
  - iv. Maximum Sign Height: Two (2) feet.
  - v. Maximum Sign Area: Seventy (70) square feet.
  - vi. Signs extending above or below a Canopy shall be raceway or pin mounted. Cabinet signs are not permitted.
  - vii. Illumination: May be Internally or Externally Illuminated.

FIGURE 6.17(E): CANOPY SIGN

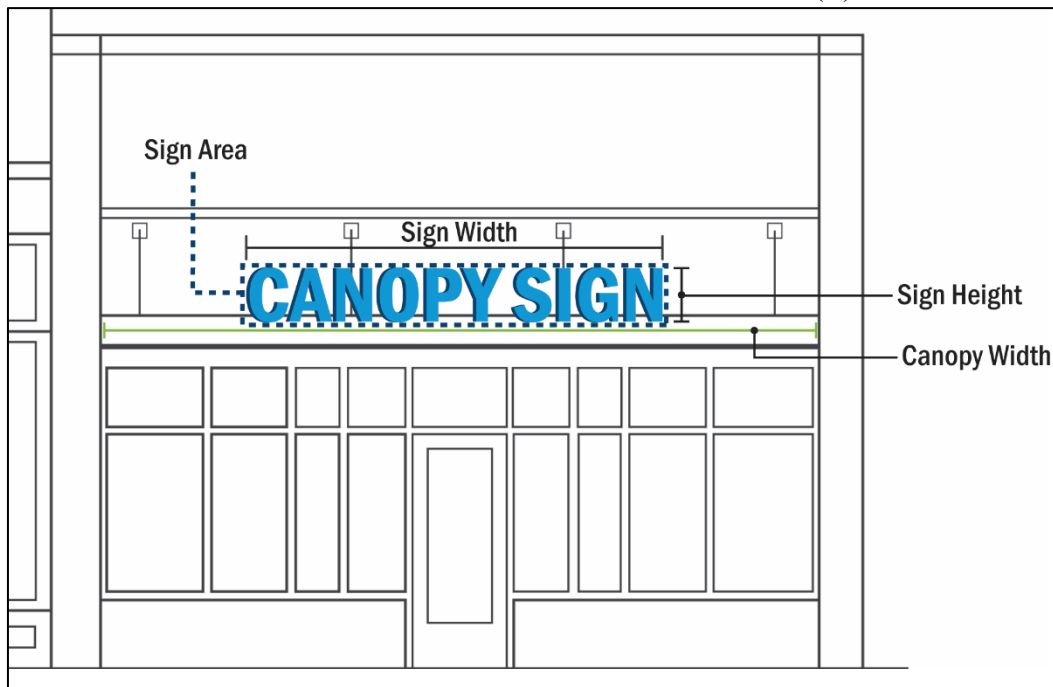

- c. Freestanding Canopy Signs:

- i. Quantity: Not to exceed one (1) per Street frontage.
  - ii. Maximum Sign Width: Twenty-five percent (25%) of the length of the Fascia.
  - iii. Maximum Sign Height: Eighty percent (80%) of the height of the Fascia.
  - iv. Maximum Sign Area: Thirty (30) square feet.
  - v. Illumination: May be Internally or Externally Illuminated.
- 5. Awning Signs: Signs printed on Awnings shall comply with the following:
  - a. Location: Shall be located on first-story awnings only.
  - b. Clearance: Sign shall maintain a minimum vertical clearance of eight (8) feet when measured from the lowest point of the Awning and a horizontal clearance of two (2) feet from the back of a curb.
  - c. Quantity: Not to exceed one (1) per Awning face.
  - d. Maximum Sign Width: Seventy-five percent (75%) of the length of the applicable Awning face.
  - e. Maximum Sign Height: Text and graphics may not exceed two (2) feet in height on the front and side valances
  - f. Maximum Sign Area: Signs on the sloped plane may not exceed fifty percent (50%) of the area of the plane.
  - g. Illumination: May be externally illuminated by a fixture located above the awning structure. Backlit awnings are not permitted.
- 6. Ground Signs: Ground Signs shall be limited to Monument Signs and Post Signs. All Ground Signs shall comply with the following unless otherwise stated in this Article:
  - a. General Standards:
    - i. Quantity: One (1) per Lot.
    - ii. Maximum Sign Area: Sixty (60) square feet per Sign Face. Sign caps and bases shall not be used for tenant display purposes and shall not count towards the Sign Area calculation.
    - iii. Maximum Sign Width: Twelve (12) feet.
    - iv. Illumination:
      - (a) Business and Industrial Districts: Ground Signs within Business and Industrial Districts may be Internally or Externally Illuminated.
      - (b) Signs within Agricultural and Residential Districts: Ground Signs within Signs within Agricultural and Residential Districts may not be Internally Illuminated.
  - b. Post Signs: In addition to standards generally applicable to Ground Signs, Post Signs shall comply with the following:
    - i. Maximum Sign Height: Six (6) feet.
    - ii. Sign Posts: Wood posts shall be painted, finished, or sealed. All Sign posts shall be topped with a decorative cap.
  - c. Monument Signs: In addition to standards generally applicable to Ground Signs, Monument Signs shall comply with the following:

- i. Maximum Height: Nine (9) feet. Total aggregate Sign cap and base height shall not exceed three (3) feet for single-tenants Signs and six (6) feet for Center Signs.
  - ii. Sign Base: Monument Signs shall incorporate a sign base consisting of Masonry Materials matching or complimenting the color, texture, or theming of the development. The Sign base shall have a minimum height of six (6) inches and a minimum cap height of two (2) inches. The width of the Sign base shall be at least eighty (80) percent of the entire width of the Sign Board.
  - iii. Landscaping: Landscaping shall be provided around the base of a Monument Sign.
- d. Pole Signs: Pole Signs are prohibited.

FIGURE 6.17(F): GROUND SIGN TYPES

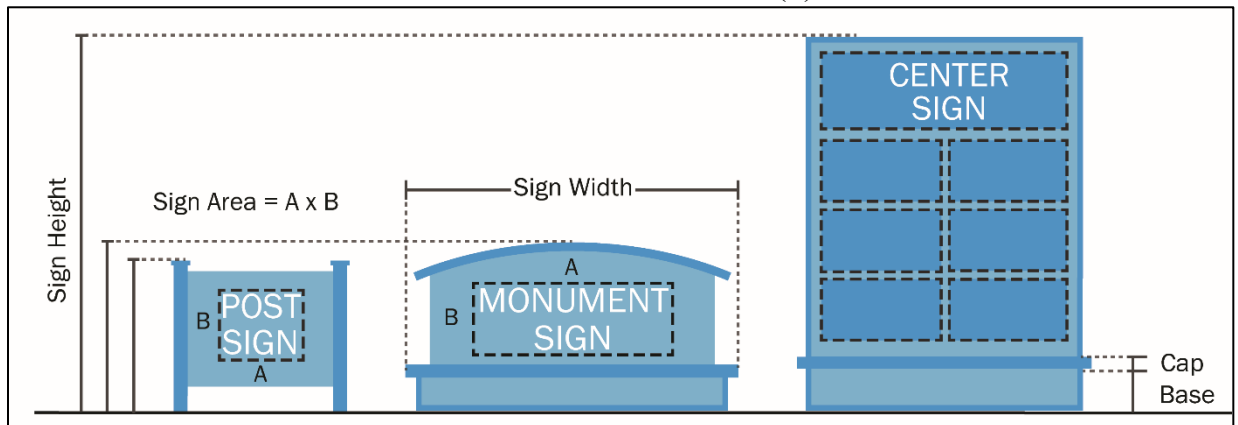

7. Window Signs: All Window Signs shall comply with the following unless otherwise stated in this Article:
- a. Maximum Sign Area: The aggregate area of all Window Signs, including Internally-Illuminated Signs, shall not exceed 25% of the cumulative window area of the building or tenant space per facade.
  - b. Illumination:
    - i. Nonresidential Uses shall be permitted one (1) Internally Illuminated Window Sign, not to exceed three (3) square feet. The Sign may be illuminated only during operating hours, and shall not flash, blink, or otherwise give the appearance of movement.
    - ii. Internally Illuminated Signs in excess of three (3) square feet shall be considered Wall Signs and subject to the applicable Wall Sign standards.

#### K. Residential Signs:

1. Subdivision Signs: Single-family and Multi-family subdivisions shall be permitted signage as follows. Ground Signs and Entrance Features shall be located within a platted Common Area or Subdivision Sign Easement.
  - a. Primary Subdivision Entrances:
    - i. Ground Signs:
      - (a) Quantity: One (1) Ground Sign or entrance feature per entrance into a subdivision from an External Street.
      - (b) Maximum Sign Height: Nine (9) feet not including the Sign cap, if provided.
      - (c) Maximum Sign Area: Thirty-two (32) square feet. All sides of a Sign shall deduct from the Sign Area Allocation.
    - ii. Entrance Features Incorporating Signage:
      - (a) In lieu of a Ground Sign, up to two (2) separate Sign display areas may be directly incorporated into a larger decorative entrance feature such as a wall, decorative fence, fountain, raised planting bed, or similar structure located on one or both sides of a development entrance.
      - (b) Quantity: One (1) Entrance Feature or Ground Sign per entrance into a subdivision from an External Street.
      - (c) Maximum Height: The entrance feature may not exceed fifteen (15) feet in height. The maximum height may be increased for entrance features designed to overhang a vehicular entrance, such as timber beams or a covered gate. Any increase to the maximum height shall be subject to Director discretion.
      - (d) Maximum Sign Area: The total area of the identification portion(s) of the entrance feature may not exceed fifty (50) feet.
  - b. Secondary Subdivision Entrances:
    - i. Any entrance into a subdivision not from an External Street shall be considered a secondary entrance. Examples include:
      - (a) An entrance into a Subdivision from a Local Street,
      - (b) An entrance into a distinct area or section within a larger Subdivision, or
      - (c) An entrance into a Subdivision from an external pedestrian path or trail.
    - ii. Quantity: One (1) Ground Sign per secondary entrance.
    - iii. Maximum Sign Height: Six (6) feet or nine (9) feet if incorporating Sign base and Sign cap features.
    - iv. Maximum Sign Area: Sixteen (16) square feet.
  - c. Wall Signs: Shall not exceed four (4) square feet.
2. Mixed-Use Residential Building Signs: Residential Uses in mixed-use Buildings shall be permitted Wall Signs and Blade Signs as follows:

- a. Quantity: Each Building shall be permitted either two (2) Wall Signs or one (1) Wall Sign and one (1) Blade Sign.
  - b. Sign Area: The total Sign Area Allocation permitted shall be one-half (.5) square foot of Sign Area for each one (1) linear foot of Building Façade fronting on a public Right-of-way. Signs shall only be located on the Building Façade from which the Sign Area Allocation was derived.
  - c. Maximum Sign Area: Wall Signs may not exceed one hundred and twenty (120) square feet per Sign.
  - d. Location: With the exception of Blade Signs extending from the corner of a Building, the Signs shall not be located on the same frontage.
  - e. Signs for nonresidential tenants of mixed-use Residential Buildings shall be regulated per the Nonresidential Center standards set forth in this Article.
  - f. Signs for parking garages shall be regulated per the standards set forth in this Article.
3. Home Business Signs:
- a. Home Businesses shall be permitted one (1) Sign per Dwelling not to exceed four (4) square feet in total Sign area.
  - b. Home Business Signs shall only be affixed to a wall or door of the Structure containing the business.

L. Nonresidential Signs:

1. Individual Nonresidential Signs: All Individual Nonresidential Uses, including permitted Nonresidential Uses in Residential Districts, shall be permitted Ground Signs, Wall Signs, Awning Signs, Canopy Signs, Blade Signs, Projecting Signs, and Window Signs as set forth below, unless otherwise permitted by this Article. Outlots of Nonresidential Centers are not considered individual Uses and shall be regulated as set forth in the Nonresidential Center Sign standards section of this Article.
  - a. Sign Area: The total Sign Area Allocation permitted shall be one (1) square foot of Sign Area for each one (1) linear foot of Building Façade fronting on a public Right-of-way.
2. Parking Garage Signs: All parking garages, including garages integrated within a larger Building, shall be permitted signage as follows:
  - a. Quantity: One (1) Projecting Sign and one (1) Wall Sign per vehicular entrance.
  - b. Maximum Sign Area:
    - i. Wall Sign: Thirty-five (35) square feet
    - ii. Projecting Sign: Thirty-two (32) square feet
  - c. Electronic Sign Components:
    - i. Parking garages with spaces open to the public shall be permitted one (1) additional Wall Sign or Ground Sign per vehicle entrance. This sign must include (1) or more Electronic Sign components.
    - ii. The Sign shall not exceed fifteen (15) square feet, and the electronic display area of each individual Electronic Sign component shall not exceed one (1) square foot.



- i. Quantity: One (1) per tenant per public entrance.
    - ii. Maximum Sign Area: Not to exceed six (6) square feet.
    - iii. Suspended-style Projecting Signs are encouraged in the Downtown area. Sign brackets shall be decorative in nature.
  - e. Window Signs:
    - i. Location: Shall be located only on windows at the pedestrian grade.
    - ii. Maximum Sign Area: The aggregate area of all Window Signs, including Internally-Illuminated Signs, shall not exceed 25% of the total window area of the building or tenant space.
    - iii. Maximum Coverage: Signage shall not cover more than fifty (50) percent of a single window.
    - iv. Signs shall greater than four (4) square feet shall be etched, painted, or otherwise permanently affixed to the window.
  - f. Illumination: Signs may be illuminated as permitted by this Article. Internally Illuminated Signs shall be reverse channel or halo-lit only; front lit Signs are not permitted. Wall-mounted or sign-mounted lighting fixtures for Externally Illuminated Signs shall be decorative in nature.
  - g. Signs for parking garages shall be regulated per the Parking Garage standards set forth in this Article.
- 4. Nonresidential Center Signs: All multi-tenant developments shall be permitted Signage as follows:
  - a. Sign Plan: A Sign plan shall be submitted for a Nonresidential Center prior to receiving the first Sign permit for the center or a center tenant. The Sign plan shall include:
    - i. A site plan, to scale, depicting the location of all permanent Signs.
    - ii. Building elevations, to scale, depicting the approximate location of all Wall, Awning, Canopy, Under Canopy, and Projecting Signs.
    - iii. Description of uniform lighting method (for example: reverse channel, channel, panel, exterior above, or exterior below lighting).
    - iv. Landscape Plan for all Monument Signs.
  - b. Monument Signs: Nonresidential Centers shall be permitted Monument Signs as follows:
    - i. Center Sign: Shall be permitted one (1) per Nonresidential Center not to exceed the following:
      - (a) Nonresidential Centers less than ten (10) acres in size (not including public Rights-of-way): Nine (9) feet in Sign Height and sixty (60) square feet of Sign Area per Sign Face.
      - (b) Nonresidential Centers ten (10) to fifteen (15) acres in size (not including public Rights-of-way): Fifteen (15) feet in Sign Height and one hundred and twenty (120) square feet of Sign Area per Sign Face.
      - (c) Nonresidential Centers greater than fifteen (15) acres in size (not including public Rights-of-way): Twenty-five (25) feet in

Sign Height and two hundred and fifty (250) square feet of Sign Area per Sign Face.

- ii. Entrance Signs: In addition to a center Monument Sign, Nonresidential Centers shall be permitted one (1) Entrance Monument Sign per entrance into the Nonresidential Center from an External Street, not to exceed six (6) feet in Sign Height and thirty (30) square feet of Sign Area per Sign Face.
- c. Incidental Signs: Unless otherwise stated in this Article, Nonresidential Centers shall be permitted Incidental Signs as follows:
  - i. Incidental Signs may be in the form of any permitted Sign type, subject to the standards of this Article, and may be Internally or Externally-Illuminated.
  - ii. The Sign Area of an Incidental Sign shall not deduct from the Sign Area Allocation of an associated Center or Outlot.
  - iii. The Director shall determine whether a Sign is an Incidental Sign based on the visibility of the sign from the lot line or right-of-way, the number of signs in close proximity of each other, and the presence of a Commercial Message. An Incidental Sign may be denied if it is determined that the Sign already regulated by another standard in this Article.
- d. In-Line Tenant Signs: All in-line tenants, including those within multi-story nonresidential buildings or mixed-use residential buildings, shall be permitted shall be permitted Wall Signs, Awning Signs, Canopy Signs, Under Canopy Signs, Projecting Signs, and Window Signs as set forth below. In-line tenants shall not be permitted individual Ground Signs.
  - i. Sign Area Allocation:
    - (a) Front Façade: Two (2) square feet of signage of each linear foot of the tenant's front Building Façade. All in-line tenants shall have only one (1) front façade, that being the Building Façade with the tenant's primary public entrance.
    - (b) Side & Rear Façades: One (1) square foot of signage for each linear foot of the tenant's side or rear Building Façade.
    - (c) In the event that it is unclear how much of a Building Façade can be claimed by each tenant, the Sign Area Allocation shall be divided evenly among the number of In-Line tenants.
  - ii. Location: Signs shall be located on the Building Façade from which its Sign Area Allocation was derived.
  - iii. Sign Area: Under Canopy and Projecting Signs not exceeding three (3) square feet shall not subtract from the Sign Area Allocation.
  - iv. Sign Height: Wall Signs for In-line Tenants within multi-story Buildings may be located above the ground floor but shall not exceed twenty-six (26) feet above grade.

- e. Multi-Tenant Building Signs: Buildings containing one (1) or more nonresidential tenants without a storefront or dedicated public entrance shall be permitted Wall, Awning, Blade, and Projecting Signs as set forth below:
  - i. Quantity: Each Building shall be permitted signage as per the following chart, not to exceed four (4) Signs in total. Permitted Signs may be placed on any Building Façade, but no single tenant shall be permitted more than one (1) Sign on a single Building Façade.

Chart: Multi-Tenant Building Signage

Length of Building Frontage	Number of Signs Allowed
0 to 199 feet	1
200 to 399 feet	2
400 feet or greater	3

- ii. Sign Area Allocation:
    - (a) One & Two-story Buildings: One (1) square foot of signage per linear foot of Building Façade adjacent to a Public Right-of-way or internal drive providing circulation through the Nonresidential Center.
    - (b) Three-story or Greater Buildings: Two (2) square feet of signage for each linear foot of Building Façade adjacent to a Public Right-of-way or internal drive providing circulation through the Nonresidential Center.
    - (c) The Sign Area Allocation shall not be used to increase the Sign Area Allocation of an In-line Tenant, if present.
  - i. Location: Wall Signs shall be located at or near the top edge of the Building Façade and distributed across the facade symmetrically, evenly, or in a manner that aesthetically compliments the design of the Building Façade.
  - ii. Building Identification: In addition to the Signage above, one (1) nonilluminated Wall, Canopy, Awning Sign, or transom window Sign shall be permitted per patron entrance for the purposes of building identification, not to exceed six (6) square feet.
- f. Outlot Building Signs: Outlot Buildings shall be permitted Wall Signs, Awning Signs, Under Canopy Signs, Canopy Signs, Projecting Signs, and Blade Signs in accordance with the following:
- i. Sign Area Allocation: All Outlots shall be permitted one (1) square foot of Sign Area per one (1) linear foot of Building Façade fronting a Public Right-of-way or an internal drive providing circulation through a Nonresidential Center.
  - ii. Location: Signs may be located on any Building Façade regardless of the Building Façade from which the Sign Area Allocation was derived.

- iii. Outlots within Nonresidential Centers shall not be permitted individual Ground Signs.
  - 5. **Drive-through Signs:** Buildings containing a Drive-through shall be permitted Drive-through Signs in accordance with the following:
    - a. **Quantity:** One (1) primary Sign and one (1) secondary Sign shall be permitted per Drive-through lane. These Signs shall be permitted in addition to other Signs permitted by this Article and the Sign Area shall not deduct from the Building's Sign Area Allocation.
    - b. **Sign Area and Height:**
      - i. Primary Signs shall have a maximum Sign Height of six (6) feet with a maximum Sign Area of forty (40) square feet.
      - ii. Secondary Signs shall have a maximum Sign Height of six (6) feet with a maximum Sign Area of fourteen (14) square feet.
    - c. Primary and secondary Signs shall have a Sign base matching or architecturally compatible with the primary exterior Building material.
    - d. Both Signs may utilize digital Sign panels in accordance with the Electronic Sign standards of this Article.
  - 6. **Gasoline Service Stations:** Individual Nonresidential Sign standards shall apply to Gasoline Service Stations, except as modified below:
    - a. **Fuel Canopies:** Signage for Canopies associated with Gasoline Service Stations shall be regulated as per the Freestanding Canopy Sign Standards set forth in this Article, except as modified below:
      - i. **Quantity:** One Sign (1) per Street Frontage, not to exceed one (1) Sign per side.
      - ii. **Maximum Sign Area:** Fifteen (15) square feet per Sign.
    - b. **Electronic Signs:**
      - i. Gasoline Service Stations shall be permitted one (1) Monument Sign, which may include Electronic Sign components.
      - ii. For Gasoline Service Stations in Nonresidential Centers, Electronic Sign components shall be permitted on two (2) Monument Signs (including a Center Sign) if the Signs are located on separate Street frontages or at least four hundred (400) feet apart.
      - iii. Electronic Sign components are not permitted on fuel canopy.
- M. **Temporary Signs Requiring a Sign Permit:** The following Signs shall require a Sign Permit but shall not count against the Property's Sign Area Allocation:
- 1. **Banner Signs:**
    - a. **Quantity:** One (1) per Use, per Street Frontage.
    - b. **Maximum Sign Area:** Thirty-two (32) square feet.
    - c. **Maximum Sign Height:** Eight (8) feet.
    - d. **Maximum Sign Length:** Ten (10) feet.
    - e. **Frequency:** Shall be limited to fifteen (15) consecutive days per quarter.
  - 2. **Temporary Freestanding Sign for Nonresidential Uses:**
    - a. **Quantity:** One (1) per Lot.

- b. Maximum Sign Area (per side): Thirty-two (32) square feet per Sign Face.
- c. Maximum Sign Height: Eight (8) feet.
- d. Maximum Sign Length: Ten (10) feet.
- e. Duration: Six (6) months. The Sign Permit can be extended one (1) time for an additional 6 months. Upon expiration of the extension, the Sign Board shall be removed for a minimum of ninety (90) days, at which time a new application will be required.
- f. Frequency: No more than two (2) Temporary Freestanding Sign permits or one (1) Temporary Freestanding Sign permit and one (1) extension shall be issued for a single lot within a fifteen (15) month period.

FIGURE 6.17(H): TEMPORARY SIGN TYPES

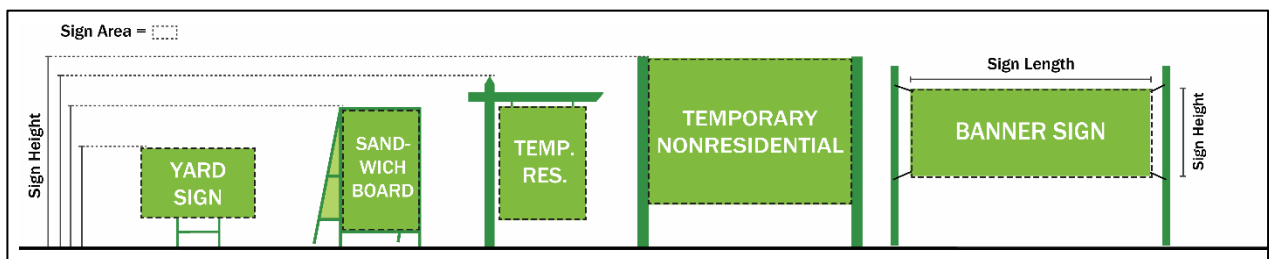

- N. **Signs Not Requiring a Permit:** The following Signs do not require a Sign Permit and do not deduct from a Property's Sign Area Allocation.
1. Address numbers.
  2. Flags.
  3. Regulatory devices and postings required by any governmental body, statute, or ordinance.
  4. Traffic control, wayfinding, directional, identification, and informational Signs placed by a governmental body to serve a government function or public purpose.
  5. Historic or memorial markers placed under the authority or with the authorization of the local, state, or federal government.
  6. Signs located within a stadium, athletic field, outdoor shopping center, or public plaza that are designed and placed so as to be viewable primarily by persons within the site.
  7. Temporary Window Signs.
  8. Incidental, non-illuminated Wall, Window, and Ground Signs not exceeding three (3) square feet in area and three (3) feet in height.
  9. Signs placed directly onto a licensed and operable motor vehicle or trailer operating in the normal course of business provided that a vehicle or trailer is not parked or positioned solely for advertising purposes.
  10. Murals and painted window displays not containing a Commercial Message.
  11. On-premises Yard Signs:
    - a. Quantity: One (1) per Use, per Street Frontage.
    - b. Maximum Sign Area: Six (6) square feet per Sign Face.
    - c. Maximum Sign Height: Three (3) feet.
    - d. Duration: Thirty (30) days.

12. Off-Premises Yard Signs:
  - a. Quantity: One (1) per Use, per Street Frontage.
  - b. Maximum Sign Area: Six (6) square feet per Sign Face.
  - c. Maximum Sign Height: Three (3) feet.
  - d. Duration: Five (5) days.
13. Temporary Freestanding Sign for Residential Uses:
  - a. Quantity: One (1) per Use, per Street Frontage.
  - b. Maximum Sign Area: Six (6) square feet per Sign Face.
  - c. Maximum Sign Height: Three (3) feet.
  - d. Duration: Six (6) months.
14. Sandwich Board Signs:
  - a. General:
    - i. Maximum Sign Area: Six (6) square feet per Sign Face.
    - ii. Maximum Sign Height: Three (3) feet.
    - iii. Maximum Opening Depth: Three and one-half (3.5) feet when measured from the outside of a Sign support and/or Sign face.
    - iv. Support: Shall have a weighted base support to ensure Sign stability.
    - v. Signs shall not include Electronic Sign or changeable copy components.
  - b. Residential Uses:
    - i. Quantity: One (1) per Street Frontage.
    - ii. Duration: Seven (7) days.
  - c. Nonresidential Uses:
    - i. Quantity: One (1) per individual Nonresidential Use.
    - ii. Location: Signs shall only be placed within ten (10) feet of, and directly in front of, a Building Façade having a public entrance.
    - iii. Timing: Signs can only be present when the associated business is open and must be removed at the end of each business day.
15. Temporary Signs During Election Season: In compliance with Indiana Code 36-1-3-11, Temporary Signs shall be permitted as follows during Election Season, a period of time beginning sixty (60) calendar days before an election and ending six (6) days after an election:
  - a. Maximum Sign Area: Thirty-two (32) square feet.
    - i. If a Sign consists of two (2) faces, only the surface area of one (1) of the faces is considered if the following apply:
      - (a) The faces are mounted back to back
      - (b) The measure of the angle between the faces is not more than fifteen (15) degrees.
  - b. Location: Signs shall not be located within a public Right-of-Way, Vision Clearance Triangle, or in a manner that impairs lines of sight for vehicles or pedestrians.

- c. A Sign permit is not required for Temporary Signs placed during Election Season, but may be required for Signs remaining past the end of the Election Season.

FIGURE 6.17(I): ANGLE BETWEEN FACES

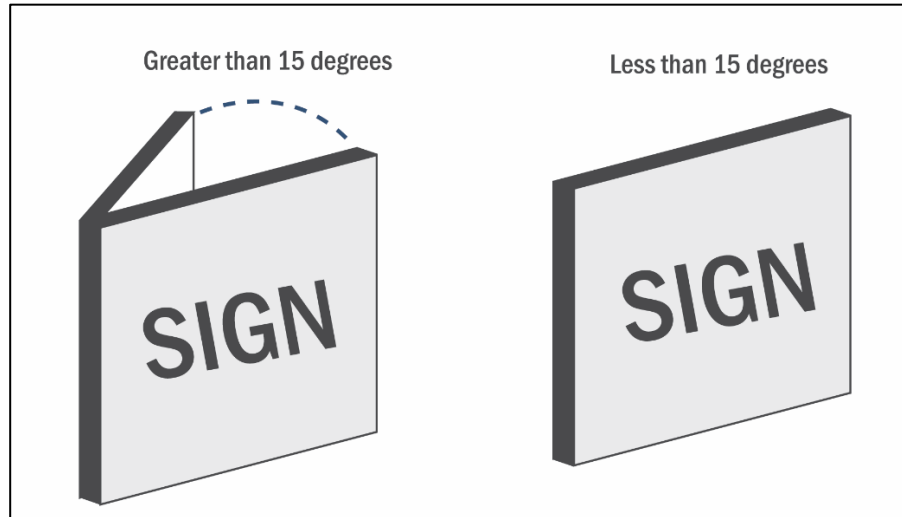

**ORDINANCE 26-01**

**AN ORDINANCE TO AMEND PROVISIONS  
IN THE WESTFIELD-WASHINGTON TOWNSHIP  
UNIFIED DEVELOPMENT ORDINANCE**

**WHEREAS**, the City of Westfield, (the “City”) is a duly formed municipal corporation within the State of Indiana, governed by its duly elected Mayor and Common Council (the “Council”); and,

**WHEREAS**, it is the duty and the responsibility of the City to administer the Westfield-Washington Township Unified Development Ordinance (the “UDO”) throughout the City and Washington Township, Indiana as identified through the adoption of a Joinder Agreement; and,

**WHEREAS**, from time to time it is necessary to amend and revise the UDO, and pursuant to I.C. § 36-7-4-602 and I.C. § 36-7-4-701, the City is authorized to amend the UDO; and

**WHEREAS**, on \_\_\_\_\_, 2026, the Westfield-Washington Township Advisory Plan Commission forwarded Petition No. 2601-ZOA-01 to the Council with a favorable recommendation in accordance with Indiana Code § 36-7-4-607; and

**NOW, THEREFORE, BE IT ORDAINED** by the Common Council of the City of Westfield, Hamilton County, Indiana, meeting in regular session, that the following provisions of the Unified Development Ordinance are amended as follows:

**Section 1.**     **Article 6.9(D)(4) Lighting Standards; Prohibitions** shall be removed.

**Section 2.**     **Article 6.9(G) Lighting Standards; Sign Lighting** shall be replaced as follows: Illumination of Signs shall be regulated by Article 6.17 Sign Standards.

**Section 3.**     **Article 6.17 Sign Standards** shall be replaced by **Exhibit A** of this Ordinance.

**Section 4.**     **Article 10.11 Processes & Permits; Sign Permits** shall be amended as follows:  
A. **Article 10.11(D) Signs Within a Floodplain:** Floodplain review shall be required for new Signs that involve significant filling, grading, or excavation within a Floodway, or that have the potential to affect flood flows.

**Section 5.**     **Article 12.1 Definitions** shall be amended as follows:

- A. Add new definition to read as follows:
1. **Awning:** A roof-like Structure, typically made of nonrigid materials, mounted above a storefront, window or door that projects from the Building wall and provides shelter from sun and rain.
  2. **Canopy:** A permanent shelter composed of rigid materials that is supported partially or entirely from the exterior wall of a Building.

3. **Canopy, Freestanding:** A Structure having a roof supported by columns that is not supported by or otherwise integrally attached to the exterior wall of a Building.
4. **Commercial Message:** Any Sign, wording, or logo that directly names or advertises a specific business, proprietary product or service, or other commercial activity. A message intended to direct attention to a political candidate or election, or a political, social, religious, or community issue, idea, or viewpoint, and not intended to encourage a commercial transaction shall not be deemed a Commercial Message.
5. **District:** See *District, Zoning*.
6. **District, Agricultural:** Shall mean and refer to individually, or collectively, the Zoning Districts listed under “Agricultural Districts” in *Article 4.1 Establishment of Districts*.
- 4.7. **District, Nonresidential:** Shall mean and refer to individually, or collectively, an Agricultural District, Business District, and/or Industrial District.
- 5.8. **Drive-through:** An accessory feature of an establishment including service units and stacking spaces that permits customers to receive services or obtain goods while remaining in or on a motor vehicle.
- 6.9. **Drive-through Lane:** The portion of a Drive-through accommodating a single line of vehicles. A Drive-through can contain multiple Drive-through Lanes.
- 7.10. **Election Season:** A period of time beginning sixty (60) days before and six (6) days after a general election, municipal election, primary election, school district election, or special election.
- 8.11. **Fascia:** Any broad, flat, horizontal surface, as the outer edge of a roof or Canopy.
- 9.12. **Mural:** A hand-formed image or design that is applied, affixed, or painted directly on a building or structure. A mural shall not include digitally printed vinyl, electronic display panels, or other mechanically produced images.
- 10.13. **Sign, Banner:** A Temporary Sign constructed of nonrigid material with or without a support frame.
- 11.14. **Sign, Blade:** A Sign extending from and oriented perpendicularly to the face or corner of a Building. Blade Signs are generally taller than they are wide with vertically oriented text and graphic elements.
- 12.15. **Sign, Canopy:** A Sign attached to, located on, or extending above the top of a Canopy.
- 13.16. **Sign, Drive-through:** A one-sided freestanding sign adjacent to and oriented towards a Drive-through Lane.

- ~~14~~.17. **Sign, Externally Illuminated:** A Sign illuminated by an independent light source aimed at the Sign for the purpose of illumination.
- ~~15~~.18. **Sign Face:** The area of a Sign on which the Sign Copy is placed or that draws attention to the sign.
- ~~16~~.19. **Sign, Freestanding Canopy:** A Sign located entirely on the Fascia of a Freestanding Canopy.
- ~~17~~.20. **Sign, Ground:** Any Sign whose primary support is permanently fixed within the ground. Ground Signs may include Monument Signs, Post Signs, and Pole Signs.
- ~~18~~.21. **Sign, Incidental:** A permanent Sign designed and located to be read by people within a specific site or development and generally not legible from external properties or rights-of-way. Examples include, but are not limited to, Signs indicating hours of operation, Signs on vending machines, ATMs, gas pumps, or retail kiosks, exterior display boards, tenant directory Signs, campus directional Signs, and other Signs intended to be read at close proximity. The Director shall determine whether a Sign is an Incidental Sign based on the visibility of the sign from the lot line or right-of-way, the number of signs in close proximity of each other, and/or the presence of a Commercial Message.
- ~~19~~.22. **Sign, Internally Illuminated:** A Sign illuminated by a light source that is contained within or concealed by the Sign structure, and Signs that are intrinsically formed by a light source; including but not limited to front-lit, halo-lit, reverse-channel letter, neon, and marquee bulb signs.
- ~~20~~.23. **Sign, On-Premises:** A Sign directing attention to a business, product, service, entertainment, or any other activity that is offered, sold, or conducted upon the Lot where the Sign is displayed.
- ~~21~~.24. **Sign, Post:** A Sign which is permanently fixed to the ground and supported by 1 (one) or more poles, posts, pillars, braces, or bases so that the bottom-most edge of the Sign face is less than six (6) feet above grade.
- ~~22~~.25. **Sign, Temporary:** A nonpermanent Sign intended for a limited time of display.
- ~~23~~.26. **Sign, Temporary Freestanding:** A freestanding Sign constructed of rigid materials intended to be displayed for a designated period. For the purposes of this definition, rigid materials shall include wood, aluminum, corrugated plastic, PVC board, and similar materials.
- ~~24~~.27. **Sign, Yard:** A Freestanding Temporary Sign constructed of rigid, lightweight, and/or non-durable materials.

B. Modify the following definitions as follows:

- 1. District, Residential:** Shall mean and refer to individually, or collectively, an Agricultural District, a Single-family District and/or Multi-family District.
- 1.2. Nonresidential Center:** A building or combination of buildings containing two (2) or more tenants, stores, service establishments, offices or other permitted Uses which are planned, platted, organized, or managed to function as a unified whole and shares one (1) or more of the following: (1) vehicular access; (2) Parking Areas; (3) signage; (4) landscaping; or (5) design theme; and/or is platted as part of a campus, Subdivision or coordinated shopping center, which may include Outlots for lease or for sale.
- 2.3. Sign:** Any name, identification, description, display, or illustration which is affixed to, painted on, or is represented directly or indirectly upon a Building, Structure, or Premises, and which conveys a Commercial Message. display or device placed on a property in any fashion which is designed, intended, or used to convey any identification, message or information other than an address number.
- 3.4. Sign, Awning:** Any advertising or display Sign located on any nonrigid material that extends from the exterior wall of a building and is supported by or attached to a frame an Awning.
- 4.5. Sign, Center:** Advertising A Sign used to identify a Nonresidential Center, which may include individual tenant advertising.
- 5.6. Sign, Electronic:** A Sign or Sign component with a fixed or changeable display composed of a series of lights, including but not limited to light emitting diodes (LED), fiber optics, or other illumination devices within an electronic display panel that may be changed through electronic or mechanical means.
- 6.7. Sign, Monument (or Ground):** A Sign which is permanently fixed to the ground by a structural base or other solid structural feature and constructed of a permanent material, such as brick or manufactured stone.
- 7.8. Sign, Pole:** A Sign which is permanently fixed to the ground and supported by one (1) or more poles, posts, or braces upon the ground, in excess of six (6) feet in height, not attached to or supported by any building, so that the bottom-most edge of the Sign face is greater than six feet (6') above grade.
- 8.9. Sign, Projecting:** A Sign attached to a building or wall and extending laterally more than eighteen (18) inches from the face of a wall mounted perpendicular to and extending away from a building face or wall. Projecting Signs are generally wider than they are tall with horizontally oriented text and graphic elements. The Sign board may be attached directly to a Building face or suspended from a bracket or frame.

~~9.10. **Sign, Sandwich Board:** A portable, On-Premises, Sign for display in front of a Building business for the specific Use of advertising that business.~~

~~10.11. **Sign, Window:** A Sign that is applied to, ~~or~~ attached to, or painted upon the exterior or interior of a window or located in such a manner within a ~~b~~Building that it is intentionally visible from the exterior of the ~~b~~Building through a window, but ~~excludes~~ shall not include merchandise window displays, seasonal window paintings not containing a Commercial Message, or Murals covering a window.~~

C. Remove the following definitions as follows:

- ~~1. **Sign, Acreage For Sale:** A Sign announcing the sale, rental, or lease of land.~~
- ~~2. **Sign, Direction:** A Sign intending to direct the safe flow of vehicular and pedestrian traffic and includes "enter," "exit," and "arrow" Signs.~~
- ~~3. **Sign, Election:** A type of Temporary Sign defined in I.C. 36-1-3-11.~~
- ~~4. **Sign, Construction:** A Sign directing attention to construction upon a property where the Sign is displayed, and bearing the name, address, or other identifier of the contractor, subcontractor, architect and/or development team.~~
- ~~5. **Sign, Gas Price:** A Sign displaying only the price of gasoline.~~
- ~~6. **Sign, Home Construction or Home Remodeling Sign:** A Temporary Sign used to advertise business entities conducting remodeling or construction work activities on a given parcel during the period that remodeling or construction activities are taking place on the given parcel.~~
- ~~7. **Sign, Illuminated:** A Sign which has characters, letters, figures, designs, or outline illuminated by electric lights or luminous tubes as a part of the Sign property, or which is illuminated by reflectors.~~
- ~~8. **Sign, Interior Circulation:** A Sign intending to direct the safe flow of vehicular and pedestrian traffic and includes "enter," "exit," and "arrow" Signs. Interior Circulation Signs are not commercial way-finding Signs.~~
- ~~9. **Sign, Nonresidential Real Estate:** A Sign announcing the sale, rental, or lease of nonresidential property.~~
- ~~10. **Sign, Nonresidential Special Event:** A Temporary Sign for a nonresidential entity, including businesses, charitable organizations, or not-for-profit corporations, which advertises grand openings, customer appreciation events, public gatherings, and other similar events as determined by the Director.~~

- ~~11. **Sign, Open House Directional:** A Temporary Sign used to advertise an open house and direct traffic to the house for sale.~~
- ~~12. **Sign, Pylon:** A Sign constructed upon the ground on a solid foundation with the Sign surface resting directly on top of such foundation and intended to identify multiple businesses.~~
- ~~13. **Sign, Real Estate:** A Sign announcing the sale, rental, or lease of real property.~~
- ~~14. **Sign, Residential Event:** A Temporary Sign utilized to advertise residential garage sales, yard sales, individual residential events, subdivision or neighborhood events and other similar events as determined by the Director.~~
- ~~15. **Sign, Residential Real Estate:** A Sign announcing the sale, rental, or lease of residential property.~~
- ~~16. **Sign, Special Event:** A Sign advertising or announcing a special community wide event or activity conducted or sponsored by or on behalf of the City, Westfield Washington Schools, a charitable organization or a not for profit corporation. A special community-wide event or activity is one that occurs not more than twice in any twelve (12) month period and seeks to attract donations, participants or customers throughout the City.~~
- ~~17. **Sign, Time and Temperature:** A Sign displaying only the current time and/or outdoor temperature.~~

**Section 8.**

This Ordinance shall be in full force and effect in accordance with Indiana law, upon the passage of any applicable waiting periods, all as provided by the laws of the State of Indiana. All ordinances or parts thereof that are in conflict herewith are hereby ordered repealed. All acts undertaken to in creation of this Ordinance are hereby ratified.

**[The remainder of this page intentionally left blank.]**

ALL OF WHICH IS ORDAINED THIS \_\_\_\_\_ DAY OF \_\_\_\_\_, 2026.  
WESTFIELD CITY COUNCIL

**Voting For**

**Voting Against**

**Abstain**

\_\_\_\_\_  
Jon Dartt

\_\_\_\_\_  
Jon Dartt

\_\_\_\_\_  
Jon Dartt

\_\_\_\_\_  
Victor McCarty

\_\_\_\_\_  
Victor McCarty

\_\_\_\_\_  
Victor McCarty

\_\_\_\_\_  
Joe Duepner

\_\_\_\_\_  
Joe Duepner

\_\_\_\_\_  
Joe Duepner

\_\_\_\_\_  
Patrick Tamm

\_\_\_\_\_  
Patrick Tamm

\_\_\_\_\_  
Patrick Tamm

\_\_\_\_\_  
Noah Herron

\_\_\_\_\_  
Noah Herron

\_\_\_\_\_  
Noah Herron

\_\_\_\_\_  
Kurt Wanninger

\_\_\_\_\_  
Kurt Wanninger

\_\_\_\_\_  
Kurt Wanninger

\_\_\_\_\_  
Chad Huff

\_\_\_\_\_  
Chad Huff

\_\_\_\_\_  
Chad Huff

ATTEST:

\_\_\_\_\_  
Marla Ailor, Clerk Treasurer

I hereby certify that ORDINANCE 26-01 was delivered to the Mayor of Westfield

on the \_\_\_\_\_ day of \_\_\_\_\_, 2026, at \_\_\_\_\_ m.

\_\_\_\_\_  
Marla Ailor, Clerk-Treasurer

I hereby APPROVE ORDINANCE 26-01

I hereby VETO ORDINANCE 26-01

this \_\_\_\_\_ day of \_\_\_\_\_, 2026.

this \_\_\_\_\_ day of \_\_\_\_\_, 2026.

\_\_\_\_\_  
Scott Willis, Mayor

\_\_\_\_\_  
Scott Willis, Mayor

This document prepared by:

Lauren Gillingham-Teague, AICP

Senior Planner

City of Westfield, Community Development Department

2728 East 171<sup>st</sup> Street, Westfield, Indiana 46074 | (317) 804-3175

I affirm, under the penalties for perjury, that I have taken reasonable care to redact each Social Security Number in this document, unless required by law: Lauren Gillingham-Teague

**EXHIBIT A**

**6.17 Sign Standards**

- A. **Purpose and Intent:** The community wishes to establish Sign regulations for the design, placement, and maintenance of Signs which provide a reasonable and impartial means to permit communication, protect the public health, safety, and general welfare, minimize hazards to pedestrians and motorists along Streets and at intersections, enhance the aesthetic environment of the community, safeguard Property values, minimize possible adverse effects of Signs on nearby Property, protect public and private investment in Buildings and open space, and implement relevant provisions of the Comprehensive Plan as updated. The community wishes to balance expressive rights with the rights of the public to have uncluttered, safe, and attractive public Rights-of-way and sightlines. The responsible regulation of Signs will foster business opportunities and improve the quality of life in the community.
- B. **Applicability:** This Article shall apply to all Signs in all Zoning Districts in the Jurisdiction of the Plan Commission, including but not limited to changes in Sign Copy. However, the owner of any Sign that is otherwise allowed by this Ordinance may substitute noncommercial copy in place of any other commercial or noncommercial copy without the issuance of a permit.
- C. **Permits:** A Sign permit shall be required for all Signs unless otherwise exempted herein. The Director shall have the authority to review and decide upon Sign permit applications. See *Article 10.11 Sign Permits*. If the proposed Sign plan complies with the requirements of this Ordinance, then a Sign permit shall be issued within twelve (12) business days of receipt of a complete Application.
- D. **Sign Calculation Standards:**
  - 1. **Sign Area:** Sign Area shall be computed as the smallest continuous perimeter enclosing the extreme limits of the Sign Copy, including all background area figures and letters. The perimeter shall not include any structural elements lying outside the limits of the Sign which are not part of the information, visual attraction, or symbolism of the Sign.

**FIGURE 6.17(A): SIGN AREA**



2. Sign Height: Sign Height shall be measured from the finished grade of the ground immediately beneath the Sign to the highest point of the Sign or Sign Structure. If the Sign is located on an artificial earthen berm, the Sign Height is measured from the highest point of the Sign to the base of the berm.
3. Sign Area Allocation: For the purposes of calculating Sign Area Allocation, the Building Façade shall include canopies, marquees, and other permanent building projections, but shall not include Awnings. Unless otherwise stated, the Sign Area Allocation shall be divided between all permitted Signs, including legally established nonconforming Signs.
4. Rights-of-way: For the purposes of this Article, the term “public Right-of-way” shall include public Streets, Private Streets, and circulation drives internal to Nonresidential Centers, but shall not include public paths or trails.
5. Absolute Minimum & Maximum Sign Area: In no instance shall a permitted nonresidential Use or in-line tenant be allocated less than twenty-five (25) square feet of Sign Area, nor shall any permitted nonresidential Use or tenant be permitted to display more than five hundred (500) square feet of Sign Area.

E. **Prohibitions**: The following shall be prohibited:

1. Signs or Sign Structures similar in coloring, shape, function, or location; or which resemble, conflict with, or may be confused with any approved traffic-control Sign or device.
2. Signs that create a safety hazard for vehicles or pedestrians, as determined by the Department of Public Works.
3. Signs placed in any Right-of-way, except publicly owned traffic-control and transit Signs, informational, identification, directional Signs, and temporary Signs, as regulated by this Article.
4. Pole Signs.
5. Off-premises Signs; except as otherwise permitted by this Article.
6. Display of ribbons, streamers, spinners, feather flags, balloons, or inflatable Signs.
7. Signs that project into the Right-of-way; except for Projecting Signs and Blade Signs as otherwise permitted by this Article.
8. Signs mounted on a roof or that extend above an eave or parapet of a Building Façade; except as otherwise permitted by this Article.
9. Signs that revolve, flash, blink, swing or appear to move.
10. Signs affixed to trees, fence posts, utility poles or other support Structures.
- ~~10.~~11. Signs affixed to Accessory Structures.
- ~~11.~~12. Signs placed on a vehicle, or trailer, movable waste container, or temporary storage container which is then parked or positioned for the primary purpose of displaying the Sign.
- ~~12.~~13. Temporary Signs with Electronic Sign or manual changeable copy components.

**F. Sign Installation and Maintenance:**

1. Maintenance and Repair:

- a. All Signs and Sign Structures shall be kept and maintained in a good state of repair and in a safe condition at all times. Maintenance and repair shall include, but not be limited to:
  - i. The replacement of defective parts.
  - ii. The replacement of missing or damaged Sign panels, supports or other components and parts.
  - iii. Cleaning Sign and Sign structure components.
  - iv. Repainting Sign and Sign structure components.

b. A Sign or Sign Structure may be taken down or removed for up thirty (30) days for the purposes of maintenance and repair.

c. Signs in disrepair for a period exceeding six (6) consecutive months shall be in violation of this Ordinance and subject to enforcement.

b.d. See Article 9.6 Nonconforming Signs for additional standards.

2. Abandoned Signs: The following shall apply to permanent Signs and Sign Structures:

- a. Sign Copy shall be removed by the Property Owner or lessee of a site upon which the Sign is located within three (3) months of the associated business or service ceasing operations on the premises.
- b. Legal Conforming Signs Structures with copy removed may remain for up to twenty-four (24) months provided that the Sign structure is maintained pursuant to this Article.
- c. Legal Nonconforming Sign Structures with copy removed may remain for up to six (6) months provided that the Sign structure is maintained pursuant to this Article. After which time, the Sign shall be considered abandoned and ~~lose Legal Nonconforming Status~~ be subject to removal in accordance with *Article 9.6 Nonconforming Signs*.
- d. For purposes of this section, “operation” refers to the activity occurring on the Property and not to the mere generation of income for the Property Owner, or the intentions of the Property Owner or any tenant or sub-tenant.

3. Sign Panel Replacement: The replacement of tenant panels within a Ground Sign or Wall Sign shall not require a Sign permit.

4. Setbacks: All Signs shall be a minimum distance of five (5) feet from all Property Lines. Internally-Illuminated Signs for Nonresidential Uses shall be setback a minimum distance of twenty-five (25) feet from any Residential Use or District.

5. Lines of Sight: All Signs shall comply with *Article 6.19 Vision Clearance Standards*.

**G. Sign Lighting:** Permanent Signs may be illuminated as follows. Otherwise, illumination standards for each Sign type shall be as outlined in Section J of this Article.

1. General Standards:

- a. All external Light Fixtures used to illuminate an outdoor Sign shall be Fully Shielded and oriented to direct all light output towards the Sign surface and away from adjacent lots and Rights-of-way.

- b. Internally-Illuminated Signs for Nonresidential Uses shall be setback a minimum distance of twenty-five (25) feet from any Residential Use or District.
- c. Lighting shall not flash, blink, or otherwise give the appearance of movement.
- d. Gaseous or LED neon tubing may be used to illuminate, outline, or form individual letters, symbols, or stylistic elements of a Sign only if integrated with a non-illuminated background or support frame.
- e. The illumination of, or light produced by, any Sign shall not increase nighttime ambient lighting conditions by more than 0.3 Foot-candles as measured at a distance recommended by the International Sign Association relative to the Sign's size. Ambient light monitors and automatic level controls shall be used to automatically reduce the brightness of the Sign at night and under cloudy or darkened conditions.

- 2. Agricultural and Residential Districts: Ground Signs in Agricultural and ~~Single-family Residential~~ Districts shall not be Internally Illuminated.

H. **Electronic Signs:** Signs with electronic display components shall comply with the following:

- 1. Except as otherwise permitted by this article, Electronic Sign components shall be limited to Monument Signs for Nonresidential uses.
- 2. The entire electronic display area of an Electronic Sign component shall count toward the permitted Sign Area, as applicable to the type of Sign (e.g., Monument Sign) and as permitted in this Article.
- 3. The maximum height of any letter, number or character shall be twenty (20) inches.
- 4. The combined area of all Electronic Sign components shall not exceed fifty percent (50%) of the Sign Area of the Sign on which it is located or sixty (60) square feet, whichever is less.
- 5. The effects or use of moving, flashing, blinking, animation, scrolling, twirling or other similar effects (including video) are prohibited.
- 6. Any image or message shall have a static display for a minimum duration of fifteen (15) seconds.
- 7. Changes of image shall be instantaneous as seen by the human eye and shall not use fading, rolling, window shading, dissolving or similar effects as part of the change.
- 8. Signs with Electronic Sign components are considered to be Internally Illuminated.

I. **Murals:** Art Murals in Nonresidential and Multi-family Districts shall comply with the following:

- 1. A permit is not required to erect, maintain, alter, or enlarge an art Mural that contains no Commercial Message.
- 2. Acknowledgement Panel: Murals may include an acknowledgement panel with the names or logos of art sponsors. This panel shall adjoin the bottom edge of the mural and shall not exceed two (2) square feet in area. Such acknowledgement panel shall not be classified as a Commercial Message.
- 3. Murals with a Commercial Message:

- a. Any Mural containing a direct Commercial Message, as defined by this Ordinance, shall be considered a Wall Sign and deduct from a Building's Sign Area Allocation.
- b. Sign Area: For the purposes of calculating Sign Area, the Sign Area shall be limited to the extent of the Commercial Message and shall not include any noncommercial illustrations or designs that may be present in the Mural.

J. **Permanent Signs Requiring a Sign Permit**: The following Signs shall require a Sign Permit:

1. Wall Signs: All Wall Signs shall comply with the following unless otherwise stated in this Article:
  - a. Location: Shall be located within the Sign Plane and shall not substantially obscure any architectural enhancements or features (e.g., brick detailing, changes in materials) of the Building Façade.
  - b. Sign Plane: Shall not exceed fifty percent (50%) of the Sign Plane.
  - c. Maximum Sign Area: Under no circumstances may a single Wall Sign exceed three hundred (300) square feet.
  - d. Illumination: May be Internally or Externally Illuminated.
  - e. Exposed raceways shall be finished to match the background wall or be integrated into the overall design of the Sign.

FIGURE 6.17(B): WALL SIGN

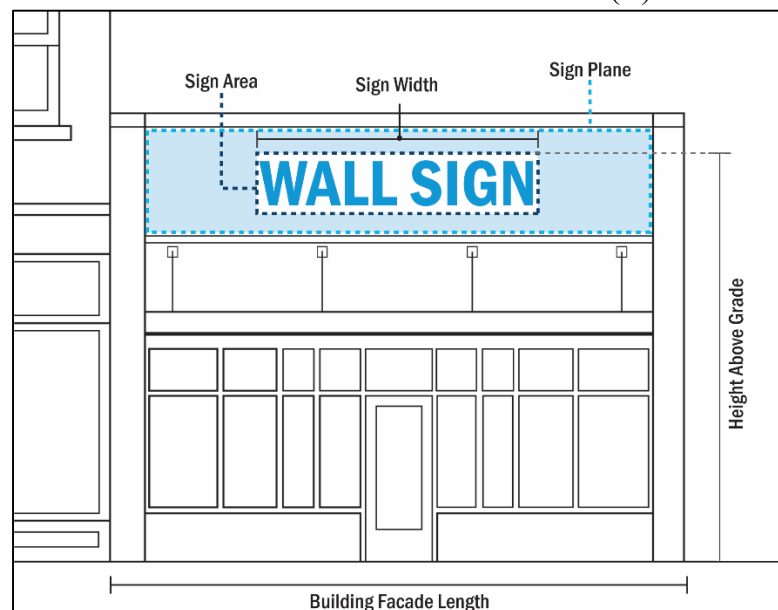

2. Projecting Signs: All Projecting Signs shall comply with the following unless otherwise stated in this Article:
  - a. Location: Projecting Signs shall be generally located on the ground floor of a Building and within eight (8) feet of a public entrance.

- b. Clearance: Sign shall maintain a minimum vertical clearance of eight (8) feet above grade when measured from the bottom of the Sign, and a minimum horizontal clearance of two (2) feet from the back of a curb.
- c. Maximum Height Above Grade: The top of the Sign Board shall not exceed the bottom of the second story windows or sixteen (16) feet above grade, whichever is less.
- d. Maximum Sign Width: Shall not extend more than five (5) feet from the face of the Building.
- e. Maximum Sign Area: Unless otherwise stated in this Article, a Projecting Sign shall not exceed twelve (12) square feet.
- f. A Projecting Sign may extend from a Building corner when adjoining an intersection. The Sign Area shall subtract from the Sign Area Allocation of both Facades.
- g. Illumination: The Sign may be Externally Illuminated by a fixture located on top of or above the sign structure. Individual letters, symbols, and stylistic elements of a Sign may be Internally Illuminated if integrated with a non-illuminated background or support frame. Internally illuminated light boxes or cabinet signs are prohibited.

FIGURE 6.17(C): PROJECTING SIGN

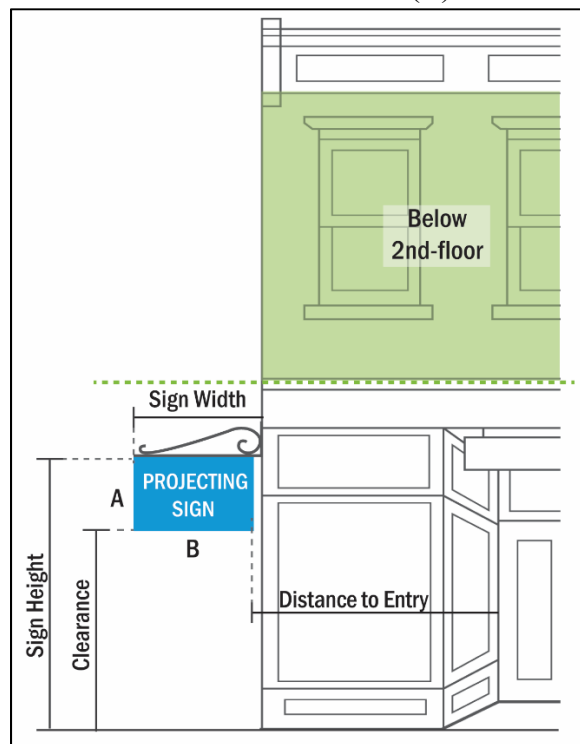

3. Blade Signs: All Blade Signs shall comply with the following unless otherwise stated in this Article:
  - a. Location: Blade Signs shall be located above the ground floor of a Building, but shall not extend above the roofline.
  - b. Quantity: Not to exceed one (1) per Building.

- c. Minimum Height Above Grade: The bottom of the Sign shall be located at or above the bottom of the second story windows or sixteen (16) feet above grade, whichever is greater.
- d. Maximum Sign Height: The height of the Sign shall not exceed sixty percent (60%) of the total height of the Building Façade above the ground floor when measured from the second-story finished floor elevation to the eaves of the roofline or the bottom of the parapet, not to exceed twenty-five (25) feet.
- e. Maximum Sign Width: Shall may not extend more than five (5) feet from the face of the Building.
- f. Maximum Sign Area: Seventy-five (75) square feet.
- g. Must be located at least twenty-five (25) feet from any other Blade Sign.
- h. A Blade Sign may be located on a Building corner when adjoining an intersection; in such case the Sign Area shall subtract from the Sign Area Allocation of both Facades.
- i. Illumination: Individual letters, symbols, and stylistic elements of a Sign may be Internally Illuminated if integrated with a non-illuminated background or support frame. Internally illuminated light boxes or cabinet signs are prohibited.

FIGURE 6.17(D): BLADE SIGN

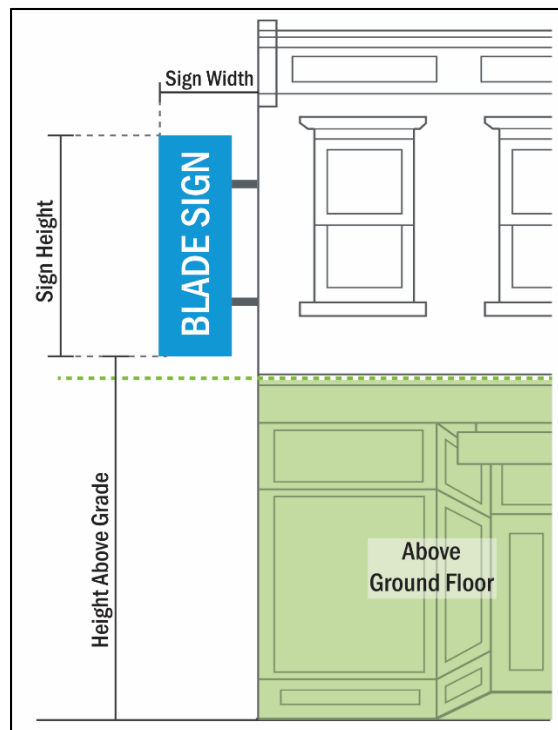

4. Under Canopy, Canopy, and Freestanding Canopy Signs: Signs attached to Canopies shall comply with the following unless otherwise stated in this Article:
  - a. Under Canopy Signs:
    - i. Location: Shall be attached to and located entirely under a canopy or roof overhang.

- ii. Quantity: Shall not exceed one (1) per public entrance per tenant.
  - iii. Clearance: Shall maintain a minimum vertical clearance of eight (8) feet when measured from the bottom of the sign.
  - iv. Maximum Sign Area: Shall not exceed two and a half (2.5) square feet.
  - v. Under Canopy Signs shall not deduct from a tenant’s Sign Area allotment.
  - vi. Illumination: Shall not be separately illuminated.
- b. Canopy Signs:
- i. Location: May be located on, above, or below the Canopy Fascia, but may not extend above a roofline or eave.
  - ii. Quantity: Shall not exceed one (1) per public entrance.
  - iii. Maximum Sign Width:
    - (a) Ninety percent (90%) of the tenant’s Canopy length if fourteen (14) feet or less.
    - (b) Seventy percent (70%) of the tenant’s Canopy length if greater than fourteen (14) feet.
  - iv. Maximum Sign Height: Two (2) feet.
  - v. Maximum Sign Area: Seventy (70) square feet.
  - vi. Signs extending above or below a Canopy shall be raceway or pin mounted. Cabinet signs are not permitted.
  - vii. Illumination: May be Internally or Externally Illuminated.

FIGURE 6.17(E): CANOPY SIGN

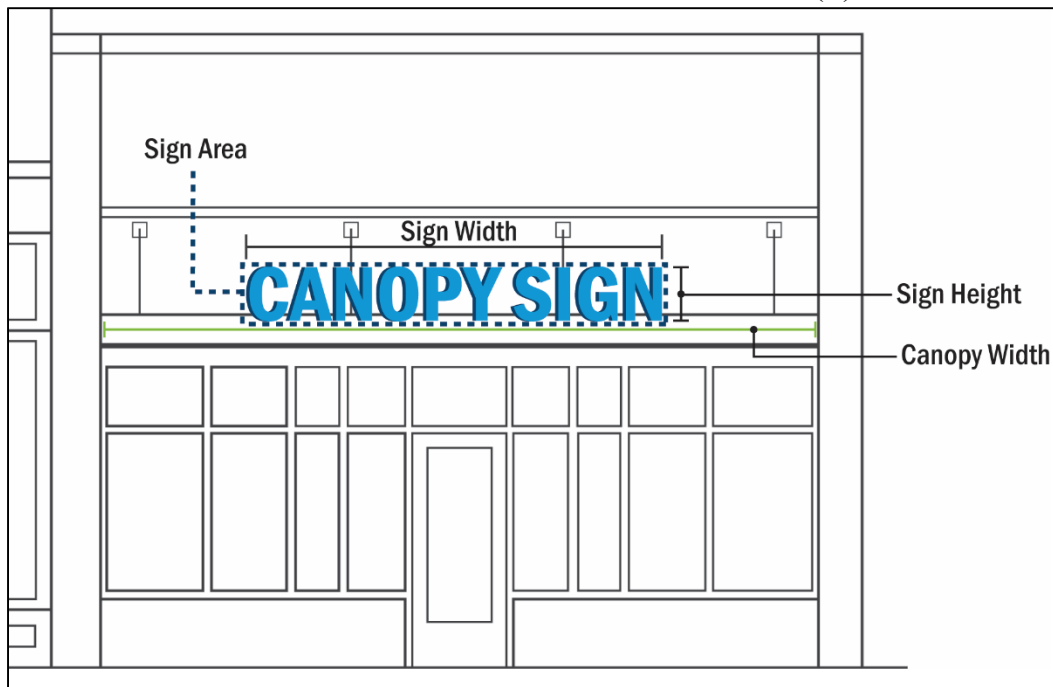

- c. Freestanding Canopy Signs:

- i. Quantity: Not to exceed one (1) per Street frontage.
  - ii. Maximum Sign Width: Twenty-five percent (25%) of the length of the Fascia.
  - iii. Maximum Sign Height: Eighty percent (80%) of the height of the Fascia.
  - iv. Maximum Sign Area: Thirty (30) square feet.
  - v. Illumination: May be Internally or Externally Illuminated.
- 5. Awning Signs: Signs printed on Awnings shall comply with the following:
  - a. Location: Shall be located on first-story awnings only.
  - b. Clearance: Sign shall maintain a minimum vertical clearance of eight (8) feet when measured from the lowest point of the Awning and a horizontal clearance of two (2) feet from the back of a curb.
  - c. Quantity: Not to exceed one (1) per Awning face.
  - d. Maximum Sign Width: Seventy-five percent (75%) of the length of the applicable Awning face.
  - e. Maximum Sign Height: Text and graphics may not exceed two (2) feet in height on the front and side valances
  - f. Maximum Sign Area: Signs on the sloped plane may not exceed fifty percent (50%) of the area of the plane.
  - g. Illumination: May be externally illuminated by a fixture located above the awning structure. Backlit awnings are not permitted.
- 6. Ground Signs: Ground Signs shall be limited to Monument Signs and Post Signs. All Ground Signs shall comply with the following unless otherwise stated in this Article:
  - a. General Standards:
    - i. Quantity: One (1) per Lot.
    - ii. Maximum Sign Area: Sixty (60) square feet per Sign Face. Sign caps and bases shall not be used for tenant display purposes and shall not count towards the Sign Area calculation.
    - iii. Maximum Sign Width: Twelve (12) feet.
    - iv. Illumination:
      - (a) Business and Industrial ~~Nonresidential~~ Districts: Ground Signs within Business and Industrial ~~Nonresidential~~ Districts may be Internally or Externally Illuminated.
      - (b) Signs within Agricultural and Residential Districts: Ground Signs within Signs within Agricultural and Residential Districts may ~~only-not~~ be ~~Externally~~ Internally Illuminated.
  - b. Post Signs: In addition to standards generally applicable to Ground Signs, Post Signs shall comply with the following:
    - i. Maximum Sign Height: Six (6) feet.
    - ii. Sign Posts: Wood posts shall be painted, finished, or sealed. All Sign posts shall be topped with a decorative cap.
  - c. Monument Signs: In addition to standards generally applicable to Ground Signs, Monument Signs shall comply with the following:

- i. Maximum Height: Nine (9) feet. Total aggregate Sign cap and base height shall not exceed three (3) feet for single-tenants Signs and six (6) feet for Center Signs.
  - ii. Sign Base: Monument Signs shall incorporate a sign base consisting of Masonry Materials matching or complimenting the color, texture, or theming of the development. The Sign base shall have a minimum height of six (6) inches and a minimum cap height of two (2) inches. The width of the Sign base shall be at least eighty (80) percent of the entire width of the Sign Board.
  - iii. Landscaping: Landscaping shall be provided around the base of a Monument Sign.
- d. Pole Signs: Pole Signs are prohibited.

FIGURE 6.17(F): GROUND SIGN TYPES

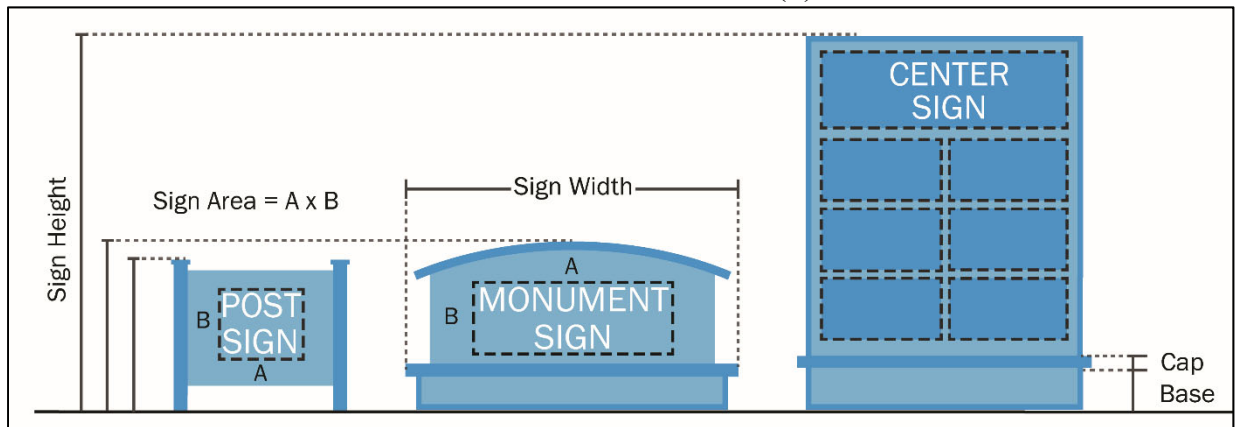

7. Window Signs: All Window Signs shall comply with the following unless otherwise stated in this Article:
  - a. Maximum Sign Area: The aggregate area of all Window Signs, including Internally-Illuminated Signs, shall not exceed 25% of the cumulative window area of the building or tenant space per facade.
  - b. Illumination:
    - i. Nonresidential Uses shall be permitted one (1) Internally Illuminated Window Sign, not to exceed three (3) square feet. The Sign may be illuminated only during operating hours, and shall not flash, blink, or otherwise give the appearance of movement.
    - ii. Internally Illuminated Signs in excess of three (3) square feet shall be considered Wall Signs and subject to the applicable Wall Sign standards.

#### K. Residential Signs:

1. Subdivision Signs: Single-family and Multi-family subdivisions shall be permitted signage as follows. Ground Signs and Entrance Features shall be located within a platted Common Area or Subdivision Sign Easement.
  - a. Primary Subdivision Entrances:
    - i. Ground Signs:
      - (a) Quantity: One (1) Ground Sign or entrance feature per entrance into a subdivision from an External Street.
      - (b) Maximum Sign Height: Nine (9) feet not including the Sign cap, if provided.
      - (c) Maximum Sign Area: Thirty-two (32) square feet. All sides of a Sign shall deduct from the Sign Area Allocation.
    - ii. Entrance Features Incorporating Signage:
      - (a) In lieu of a Ground Sign, up to two (2) separate Sign display areas may be directly incorporated into a larger decorative entrance feature such as a wall, decorative fence, fountain, raised planting bed, or similar structure located on one or both sides of a development entrance.
      - (b) Quantity: One (1) Entrance Feature or Ground Sign per entrance into a subdivision from an External Street.
      - (c) Maximum Height: The entrance feature may not exceed fifteen (15) feet in height. The maximum height may be increased for entrance features designed to overhang a vehicular entrance, such as timber beams or a covered gate. Any increase to the maximum height shall be subject to Director discretion.
      - (d) Maximum Sign Area: The total area of the identification portion(s) of the entrance feature may not exceed fifty (50) feet.
  - b. Secondary Subdivision Entrances:
    - i. Any entrance into a subdivision not from an External Street shall be considered a secondary entrance. Examples include:
      - (a) An entrance into a Subdivision from a Local Street,
      - (b) An entrance into a distinct area or section within a larger Subdivision, or
      - (c) An entrance into a Subdivision from an external pedestrian path or trail.
    - ii. Quantity: One (1) Ground Sign per secondary entrance.
    - iii. Maximum Sign Height: Six (6) feet or nine (9) feet if incorporating Sign base and Sign cap features.
    - iv. Maximum Sign Area: Sixteen (16) square feet.
  - c. Wall Signs: Shall not exceed four (4) square feet.
2. Mixed-Use Residential Building Signs: Residential Uses in mixed-use Buildings shall be permitted Wall Signs and Blade Signs as follows:

- a. Quantity: Each Building shall be permitted either two (2) Wall Signs or one (1) Wall Sign and one (1) Blade Sign.
  - b. Sign Area: The total Sign Area Allocation permitted shall be one-half (.5) square foot of Sign Area for each one (1) linear foot of Building Façade fronting on a public Right-of-way. Signs shall only be located on the Building Façade from which the Sign Area Allocation was derived.
  - c. Maximum Sign Area: Wall Signs may not exceed one hundred and twenty (120) square feet per Sign.
  - d. Location: With the exception of Blade Signs extending from the corner of a Building, the Signs shall not be located on the same frontage.
  - e. Signs for nonresidential tenants of mixed-use Residential Buildings shall be regulated per the Nonresidential Center standards set forth in this Article.
  - f. Signs for parking garages shall be regulated per the standards set forth in this Article.
3. Home Business Signs:
- a. Home Businesses shall be permitted one (1) Sign per Dwelling not to exceed four (4) square feet in total Sign area.
  - b. Home Business Signs shall only be affixed to a wall or door of the Structure containing the business.

L. Nonresidential Signs:

1. Individual Nonresidential Signs: All Individual Nonresidential Uses, including permitted Nonresidential Uses in Residential Districts, shall be permitted Ground Signs, Wall Signs, Awning Signs, Canopy Signs, Blade Signs, Projecting Signs, and Window Signs as set forth below, unless otherwise permitted by this Article. Outlots of Nonresidential Centers are not considered individual Uses and shall be regulated as set forth in the Nonresidential Center Sign standards section of this Article.
  - a. Sign Area: The total Sign Area Allocation permitted shall be one (1) square foot of Sign Area for each one (1) linear foot of Building Façade fronting on a public Right-of-way.
2. Parking Garage Signs: All parking garages, including garages integrated within a larger Building, shall be permitted signage as follows:
  - a. Quantity: One (1) Projecting Sign and one (1) Wall Sign per vehicular entrance.
  - b. Maximum Sign Area:
    - i. Wall Sign: Thirty-five (35) square feet
    - ii. Projecting Sign: Thirty-two (32) square feet
  - c. Electronic Sign Components:
    - i. Parking garages with spaces open to the public shall be permitted one (1) additional Wall Sign or Ground Sign per vehicle entrance. This sign must include (1) or more Electronic Sign components.
    - ii. The Sign shall not exceed fifteen (15) square feet, and the electronic display area of each individual Electronic Sign component shall not exceed one (1) square foot.



- i. Quantity: One (1) per tenant per public entrance.
    - ii. Maximum Sign Area: Not to exceed six (6) square feet.
    - iii. Suspended-style Projecting Signs are encouraged in the Downtown area. Sign brackets shall be decorative in nature.
  - e. Window Signs:
    - i. Location: Shall be located only on windows at the pedestrian grade.
    - ii. Maximum Sign Area: The aggregate area of all Window Signs, including Internally-Illuminated Signs, shall not exceed 25% of the total window area of the building or tenant space.
    - iii. Maximum Coverage: Signage shall not cover more than fifty (50) percent of a single window.
    - iv. Signs shall greater than four (4) square feet shall be etched, painted, or otherwise permanently affixed to the window.
  - f. Illumination: Signs may be illuminated as permitted by this Article. Internally Illuminated Signs shall be reverse channel or halo-lit only; front lit Signs are not permitted. Wall-mounted or sign-mounted lighting fixtures for Externally Illuminated Signs shall be decorative in nature.
  - g. Signs for parking garages shall be regulated per the Parking Garage standards set forth in this Article.
4. Nonresidential Center Signs: All multi-tenant developments shall be permitted Signage as follows:
- a. Sign Plan: A Sign plan shall be submitted for a Nonresidential Center prior to receiving the first Sign permit for the center or a center tenant. The Sign plan shall include:
    - i. A site plan, to scale, depicting the location of all permanent Signs.
    - ii. Building elevations, to scale, depicting the approximate location of all Wall, Awning, Canopy, Under Canopy, and Projecting Signs.
    - iii. Description of uniform lighting method (for example: reverse channel, channel, panel, exterior above, or exterior below lighting).
    - iv. Landscape Plan for all Monument Signs.
  - b. Monument Signs: Nonresidential Centers shall be permitted Monument Signs as follows:
    - i. Center Sign: Shall be permitted one (1) per Nonresidential Center not to exceed the following:
      - (a) Nonresidential Centers less than ten (10) acres in size (not including public Rights-of-way): Nine (9) feet in Sign Height and sixty (60) square feet of Sign Area per Sign Face.
      - (b) Nonresidential Centers ten (10) to fifteen (15) acres in size (not including public Rights-of-way): Fifteen (15) feet in Sign Height and one hundred and twenty (120) square feet of Sign Area per Sign Face.
      - (c) Nonresidential Centers greater than fifteen (15) acres in size (not including public Rights-of-way): Twenty-five (25) feet in

Sign Height and two hundred and fifty (250) square feet of Sign Area per Sign Face.

- ii. Entrance Signs: In addition to a center Monument Sign, Nonresidential Centers shall be permitted one (1) Entrance Monument Sign per entrance into the Nonresidential Center from an External Street, not to exceed six (6) feet in Sign Height and thirty (30) square feet of Sign Area per Sign Face.

c. Incidental Signs: Unless otherwise stated in this Article, Nonresidential Centers shall be permitted Incidental Signs as follows:

- i. Incidental Signs may be in the form of any permitted Sign type, subject to the standards of this Article, and may be Internally or Externally-Illuminated.
- ii. The Sign Area of an Incidental Sign shall not deduct from the Sign Area Allocation of an associated Center or Outlot.
- iii. The Director shall determine whether a Sign is an Incidental Sign based on the visibility of the sign from the lot line or right-of-way, the number of signs in close proximity of each other, and the presence of a Commercial Message. An Incidental Sign may be denied if it is determined that the Sign already regulated by another standard in this Article.

e.d. In-Line Tenant Signs: All in-line tenants, including those within multi-story nonresidential buildings or mixed-use residential buildings, shall be permitted shall be permitted Wall Signs, Awning Signs, Canopy Signs, Under Canopy Signs, Projecting Signs, and Window Signs as set forth below. In-line tenants shall not be permitted individual Ground Signs.

- i. Sign Area Allocation:
  - (a) Front Façade: Two (2) square feet of signage of each linear foot of the tenant's front Building Façade. All in-line tenants shall have only one (1) front façade, that being the Building Façade with the tenant's primary public entrance.
  - (b) Side & Rear Façades: One (1) square foot of signage for each linear foot of the tenant's side or rear Building Façade.
  - (c) In the event that it is unclear how much of a Building Façade can be claimed by each tenant, the Sign Area Allocation shall be divided evenly among the number of In-Line tenants.
- ii. Location: Signs shall be located on the Building Façade from which its Sign Area Allocation was derived.
- iii. Sign Area: Under Canopy and Projecting Signs not exceeding three (3) square feet shall not subtract from the Sign Area Allocation.
- iv. Sign Height: Wall Signs for In-line Tenants within multi-story Buildings may be located above the ground floor but shall not exceed twenty-six (26) feet above grade.

- d.e. Multi-Tenant Building Signs: Buildings containing one (1) or more nonresidential tenants without a storefront or dedicated public entrance shall be permitted Wall, Awning, Blade, and Projecting Signs as set forth below:
  - i. Quantity: Each Building shall be permitted signage as per the following chart, not to exceed four (4) Signs in total. Permitted Signs may be placed on any Building Façade, but no single tenant shall be permitted more than one (1) Sign on a single Building Façade.

Chart: Multi-Tenant Building Signage

Length of Building Frontage	Number of Signs Allowed
0 to 199 feet	1
200 to 399 feet	2
400 feet or greater	3

- ii. Sign Area Allocation:
  - (a) One & Two-story Buildings: One (1) square foot of signage per linear foot of Building Façade adjacent to a Public Right-of-way or internal drive providing circulation through the Nonresidential Center.
  - (b) Three-story or Greater Buildings: Two (2) square feet of signage for each linear foot of Building Façade adjacent to a Public Right-of-way or internal drive providing circulation through the Nonresidential Center.
  - (c) The Sign Area Allocation shall not be used to increase the Sign Area Allocation of an In-line Tenant, if present.
- i. Location: Wall Signs shall be located at or near the top edge of the Building Façade and distributed across the facade symmetrically, evenly, or in a manner that aesthetically compliments the design of the Building Façade.
- ii. Building Identification: In addition to the Signage above, one (1) nonilluminated Wall, Canopy, Awning Sign, or transom window Sign shall be permitted per patron entrance for the purposes of building identification, not to exceed six (6) square feet.

- e.f. Outlot Building Signs: Outlot Buildings shall be permitted Wall Signs, Awning Signs, Under Canopy Signs, Canopy Signs, Projecting Signs, and Blade Signs in accordance with the following:
  - i. Sign Area Allocation: All Outlots shall be permitted one (1) square foot of Sign Area per one (1) linear foot of Building Façade fronting a Public Right-of-way or an internal drive providing circulation through a Nonresidential Center.
  - ii. Location: Signs may be located on any Building Façade regardless of the Building Façade from which the Sign Area Allocation was derived.

- iii. Outlots within Nonresidential Centers shall not be permitted individual Ground Signs.
  - 5. **Drive-through Signs:** Buildings containing a Drive-through shall be permitted Drive-through Signs in accordance with the following:
    - a. **Quantity:** One (1) primary Sign and one (1) secondary Sign shall be permitted per Drive-through lane. These Signs shall be permitted in addition to other Signs permitted by this Article and the Sign Area shall not deduct from the Building's Sign Area Allocation.
    - b. **Sign Area and Height:**
      - i. Primary Signs shall have a maximum Sign Height of six (6) feet with a maximum Sign Area of forty (40) square feet.
      - ii. Secondary Signs shall have a maximum Sign Height of six (6) feet with a maximum Sign Area of fourteen (14) square feet.
    - c. Primary and secondary Signs shall have a Sign base matching or architecturally compatible with the primary exterior Building material.
    - d. Both Signs may utilize digital Sign panels in accordance with the Electronic Sign standards of this Article.
  - 6. **Gasoline Service Stations:** Individual Nonresidential Sign standards shall apply to Gasoline Service Stations, except as modified below:
    - a. **Fuel Canopies:** Signage for Canopies associated with Gasoline Service Stations shall be regulated as per the Freestanding Canopy Sign Standards set forth in this Article, except as modified below:
      - i. **Quantity:** One Sign (1) per Street Frontage, not to exceed one (1) Sign per side.
      - ii. **Maximum Sign Area:** Fifteen (15) square feet per Sign.
    - b. **Electronic Signs:**
      - i. Gasoline Service Stations shall be permitted one (1) Monument Sign, which may include Electronic Sign components.
      - ii. For Gasoline Service Stations in Nonresidential Centers, Electronic Sign components shall be permitted on two (2) Monument Signs **(including a Center Sign)** if the Signs are located on separate Street frontages or at least four hundred (400) feet apart.
      - iii. Electronic Sign components are not permitted on fuel canopy.
- M. **Temporary Signs Requiring a Sign Permit:** The following Signs shall require a Sign Permit but shall not count against the Property's Sign Area Allocation:
- 1. **Banner Signs:**
    - a. **Quantity:** One (1) per Use, per Street Frontage.
    - b. **Maximum Sign Area:** Thirty-two (32) square feet.
    - c. **Maximum Sign Height:** Eight (8) feet.
    - d. **Maximum Sign Length:** Ten (10) feet.
    - e. **Frequency:** Shall be limited to fifteen (15) consecutive days per quarter.
  - 2. **Temporary Freestanding Sign for Nonresidential Uses:**
    - a. **Quantity:** One (1) per Lot.

- b. Maximum Sign Area (per side): Thirty-two (32) square feet per Sign Face.
- c. Maximum Sign Height: Eight (8) feet.
- d. Maximum Sign Length: Ten (10) feet.
- e. Duration: Six (6) months. The Sign Permit can be extended one (1) time for an additional 6 months. Upon expiration of the extension, the Sign Board shall be removed for a minimum of ninety (90) days, at which time a new application will be required.
- f. Frequency: No more than two (2) Temporary Freestanding Sign permits or one (1) Temporary Freestanding Sign permit and one (1) extension shall be issued for a single lot within a fifteen (15) month period.

-FIGURE 6.17(H): TEMPORARY SIGN TYPES

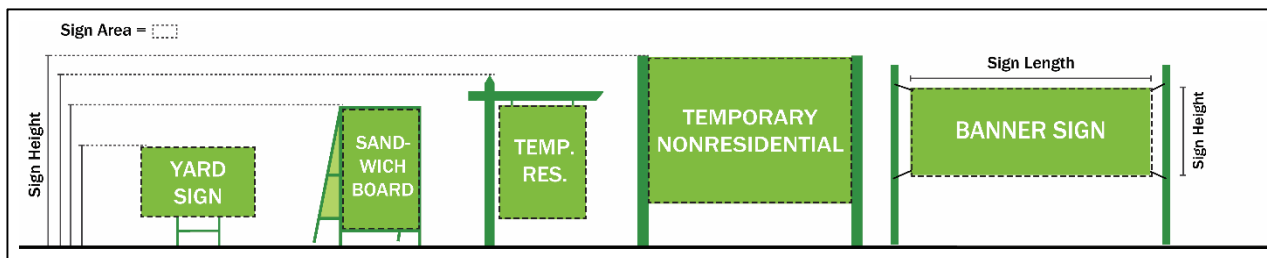

N. **Signs Not Requiring a Permit:** The following Signs do not require a Sign Permit and do not deduct from a Property's Sign Area Allocation.

1. Address numbers.
2. Flags.
3. Regulatory devices and postings required by any governmental body, statute, or ordinance.
- ~~3.~~4. Traffic control, wayfinding, directional, identification, and informational Signs placed by a governmental body to serve a government function or public purpose.
- ~~4.~~5. Historic or memorial markers placed under the authority or with the authorization of the local, state, or federal government.
- ~~5.~~6. Signs located within a stadium, athletic field, outdoor shopping center, or public plaza that are designed and placed so as to be viewable primarily by persons within the site.
- ~~6.~~7. Temporary Window Signs.
- ~~7.~~8. Incidental, non-illuminated Wall, Window, and Ground Signs not exceeding three (3) square feet in area and three (3) feet in height.
- ~~8.~~9. Signs placed directly onto a licensed and operable motor vehicle or trailer operating in the normal course of business provided that a vehicle or trailer is not parked or positioned solely for advertising purposes.
- ~~9.~~10. Murals and painted window displays not containing a Commercial Message.
- ~~10.~~11. On-premises Yard Signs:
  - a. Quantity: One (1) per Use, per Street Frontage.
  - b. Maximum Sign Area: Six (6) square feet per Sign Face.
  - c. Maximum Sign Height: Three (3) feet.

d. Duration: Thirty (30) days.

~~11~~.12. Off-Premises Yard Signs:

- a. Quantity: One (1) per Use, per Street Frontage.
- b. Maximum Sign Area: Six (6) square feet per Sign Face.
- c. Maximum Sign Height: Three (3) feet.
- d. Duration: Five (5) days.

~~12~~.13. Temporary Freestanding Sign for Residential Uses:

- a. Quantity: One (1) per Use, per Street Frontage.
- b. Maximum Sign Area: Six (6) square feet per Sign Face.
- c. Maximum Sign Height: Three (3) feet.
- d. Duration: Six (6) months.

~~13~~.14. Sandwich Board Signs:

- a. General:
  - i. Maximum Sign Area: Six (6) square feet per Sign Face.
  - ii. Maximum Sign Height: Three (3) feet.
  - iii. Maximum Opening Depth: Three and one-half (3.5) feet when measured from the outside of a Sign support and/or Sign face.
  - iv. Support: Shall have a weighted base support to ensure Sign stability.
  - v. Signs shall not include Electronic Sign or changeable copy components.
- b. Residential Uses:
  - i. Quantity: One (1) per Street Frontage.
  - ii. Duration: Seven (7) days.
- c. Nonresidential Uses:
  - i. Quantity: One (1) per individual Nonresidential Use.
  - ii. Location: Signs shall only be placed within ten (10) feet of, and directly in front of, a Building Façade having a public entrance.
  - iii. Timing: Signs can only be present when the associated business is open and must be removed at the end of each business day.

~~14~~.15. Temporary Signs During Election Season: In compliance with Indiana Code 36-1-3-11, Temporary Signs shall be permitted as follows during Election Season, a period of time beginning sixty (60) calendar days before an election and ending six (6) days after an election:

- a. Maximum Sign Area: Thirty-two (32) square feet.
  - i. If a Sign consists of two (2) faces, only the surface area of one (1) of the faces is considered if the following apply:
    - (a) The faces are mounted back to back
    - (b) The measure of the angle between the faces is not more than fifteen (15) degrees.
- b. Location: Signs shall not be located within a public Right-of-Way, Vision Clearance Triangle, or in a manner that impairs lines of sight for vehicles or pedestrians.

- c. A Sign permit is not required for Temporary Signs placed during Election Season, but may be required for Signs remaining past the end of the Election Season.

FIGURE 6.17(I): ANGLE BETWEEN FACES

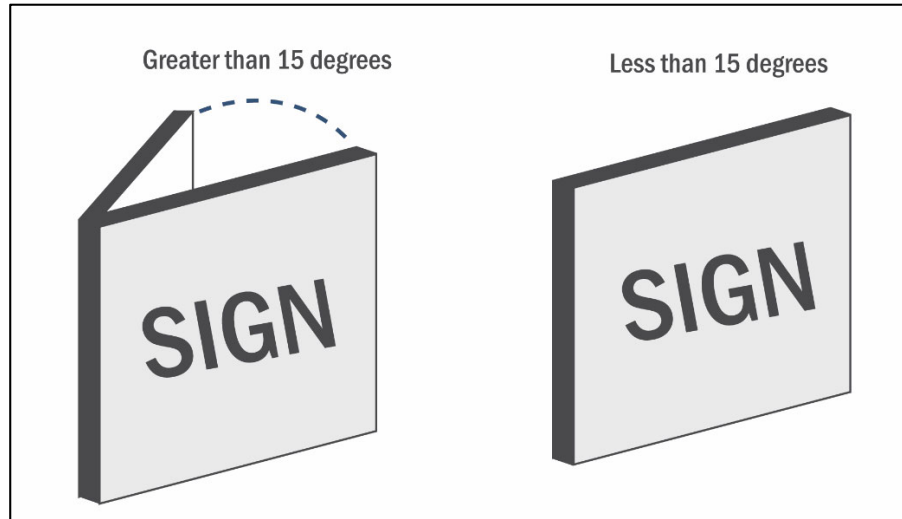



## MEMORANDUM

January 30, 2026

**TO:** Westfield-Washington City Council Members

**FROM:** Lauren Gillingham-Teague, AICP – Senior Planner

**CC:** Westfield Community Development Staff

**SUBJECT:** UDO Patch – Signs; rev. 1/30/2026

**EXHIBITS:**

1. Memorandum
2. Proposed Ord. 26-01
3. Redline of Ord. 26-01

---

Brief overview of revisions:

Art. 12.1 Definitions

Adds definitions for “Agricultural District” and “District”, and modifies the definition of “Residential District” to better align the terms used in this sign code and the UDO as a whole, which is inconsistent from chapter to chapter.

Modifies the definition of Incidental Sign to add content-neutral review criteria for determining if a sign can be classified as an Incidental Sign. Incidental Signs are permanent signs designed and located to be read by people within a specific site or development, and is most commonly used for directional or informational signs. Because this classification can apply to signs ranging anywhere from a small decal on a gas pump to a 6-foot-tall directional sign at a hospital, a degree of Director discretion is key in order to allow necessary signs without creating opportunities for the code to be abused.

Under this criteria, the Director (or a staff member) shall determine whether a sign is an Incidental Sign based on the visibility of the sign from the lot line or right-of-way, the number of signs in close proximity of each other, and/or the presence of a commercial message. While an Incidental Sign could have a commercial message, it will typically be a smaller than the informational message the sign is trying to convey, as shown in the images below.

All Incidental Signs shall be subject to this additional scrutiny, but wall, window, and post signs under 3 square feet in area and 3 feet in height shall not require a permit. Incidental Signs shall not deduct from the sign area allocation of a site. Large Incidental Signs, such as those for hospitals and campuses, are permitted only in Nonresidential Centers.



#### Art. 6.17(E) Prohibitions

Adds prohibitions on signs affixed to accessory structures and signs placed on a movable waste container or temporary storage container for the primary purpose of displaying the sign.

#### Art. 6.17(F) Sign Installation and Maintenance

Adds language found elsewhere in the UDO related to enforcement and removal of abandoned signs and signs in a long-term state of disrepair.

#### Art. 6.17(G) Sign Lighting

Adds missing word; clarifies separation of agricultural and residential districts.

#### Art. 6.17(I) Murals

Clarifies that standards apply to murals in nonresidential and multi-family districts. Murals on residential homes will continue to be regulated by HOAs. Due to the protections of the First Amendment, these standards apply only to commercial messages – a government cannot legally regulate the content of political or noncommercial murals.

The intent of these standards is not to permit murals carte blanche across the City, but rather define what is and isn't a mural and establish standards restricting the size of a commercial message within a mural. At this time, there are no regulations on murals – a building owner is permitted to paint a mural on his or her building as they please without City input or approval. It makes no difference whether it's a pleasant artistic design or a giant commercial logo (as shown below on a Carl's Jr restaurant), it would technically be permitted under the existing code. With the new code, the mural containing the giant logo would be considered a wall sign and deduct from the total sign area allocation of the site, restricting the overall size of the logo and the amount of signage permitted elsewhere on the building.

That being said, there is a provision allowing a small, 2 sq ft acknowledgement panel honoring the sponsors of the art or highlighting the mural artist's logo or social media page, similar to the mural shown below.



Art. 6.17(J)(5) Ground Signs

Clarifies applicable districts; corrects prior omission of the maximum base height for Center Signs.

Art. 6.17(L)(4)(c) Incidental Signs

Provides review criteria for Incidental Signs in Nonresidential Centers, intended for hospitals, campuses, office parks, etc.

Art. 6.17(L)(6) Gasoline Service Stations

Adds clarifying language for gas stations in Nonresidential Centers.

Art. 6.17(M)(2) Temporary Freestanding Sign for Nonresidential Uses

Adds duration and frequency limits for sign type, requires a 90-day cool down period between permits.

Art. 6.17(N) Signs Not Requiring a Permit

Adds government traffic control, wayfinding, directional, identification, and informational signs.

Clarifies type and size of Incidental Signs permitted without a permit.

Please do not hesitate to contact me with any questions, comments, or concerns.

Lauren Gillingham-Teague, AICP – Senior Planner

[Lgillingham@westfield.in.gov](mailto:Lgillingham@westfield.in.gov)

**ORDINANCE 26-04**

**AN ORDINANCE OF THE COMMON COUNCIL OF THE CITY  
OF WESTFIELD, INDIANA, AUTHORIZING AND APPROVING AN  
ADDITIONAL APPROPRIATION FROM THE OPERATING BALANCE OF THE  
CAPITAL PROJECTS FUND**

**WHEREAS**, the City of Westfield, Indiana (“City”) is a duly formed municipal corporation within the State of Indiana, governed by its duly elected Mayor and Common Council (“Council”);

**WHEREAS**, at times, it is necessary to appropriate funds within the approved budget pursuant to Ind. Code § 36-4-7-8;

**WHEREAS**, the unencumbered balance in the Capital Projects Fund No. 266 as of December 31, 2026, is currently projected to exceed \$4,380,000;

**WHEREAS**, the City desires to appropriate an additional \$4,380,000 from the Capital Projects Fund No. 266; and

**WHEREAS**, the City properly followed the notice procedures established by Ind. Code § 6-1.1-18-5 (including submission of specific information to the Department of Local Government Finance’s computer gateway), and held a public hearing on the proposed appropriation.

**NOW, THEREFORE, BE IT ORDAINED** by the Common Council of the City of Westfield, Indiana, that:

Section 1.     Recitals. The foregoing recitals are fully incorporated herein by reference.

Section 2.     Additional Appropriation. The Council hereby appropriates the following additional sums of money from the Capital Projects Fund No. 266, subject to applicable laws.

From:  
Fund No. 266 operating balance - \$4,380,000

To:  
RDC (#018) Capital Outlays Line item # 266018474 - \$4,380,000

Section 3. The Council, pursuant to its power and ability to manage the finances of the City (Ind. Code § 36-4-4-4), authorizes and directs the Clerk Treasurer to take all actions necessary to efficiently implement the appropriation specified herein.

Section 4. All other City ordinances, code sections, resolutions, or parts thereof in conflict with the provisions and intent of this ordinance are hereby repealed.

Section 5. Should any parts of this ordinance be found unconstitutional or illegal, the remaining parts shall survive and be in full effect.

Section 6. This ordinance shall be in full force and effect from and after its passage by the Council and approval by the Mayor, and in accordance with Indiana law.

PASSED THIS \_\_\_\_\_ DAY OF \_\_\_\_\_, 2026, BY THE WESTFIELD COMMON COUNCIL, HAMILTON COUNTY, INDIANA.

**WESTFIELD COMMON COUNCIL**

<u>Voting For</u>	<u>Voting Against</u>	<u>Abstain</u>
_____ Kurt J Wanninger	_____ Kurt J Wanninger	_____ Kurt J Wanninger
_____ Chad Huff	_____ Chad Huff	_____ Chad Huff
_____ Patrick T. Tamm	_____ Patrick T. Tamm	_____ Patrick T. Tamm
_____ Joe Duepner	_____ Joe Duepner	_____ Joe Duepner
_____ Jon Dartt	_____ Jon Dartt	_____ Jon Dartt
_____ Noah Herron	_____ Noah Herron	_____ Noah Herron

\_\_\_\_\_  
Victor McCarty

\_\_\_\_\_  
Victor McCarty

\_\_\_\_\_  
Victor McCarty

ATTEST:

\_\_\_\_\_  
Marla Ailor, Clerk-Treasurer

I hereby certify that ORDINANCE 26-04 was delivered to the Mayor of Westfield on the \_\_\_\_\_ day of \_\_\_\_\_, 2026, at \_\_\_\_\_ m.

\_\_\_\_\_  
Marla Ailor, Clerk-Treasurer

I hereby APPROVE ORDINANCE 26-04

I hereby VETO ORDINANCE 26-04

this \_\_\_\_\_ day of \_\_\_\_\_,  
2026.

this \_\_\_\_\_ day of \_\_\_\_\_,  
2026.

\_\_\_\_\_  
Scott A. Willis, Mayor

\_\_\_\_\_  
Scott A. Willis, Mayor

I affirm under the penalties for perjury, that I have taken reasonable care to redact each Social Security Number in this document unless required by law. /s/ Kelley Kemper

## ORDINANCE 26-05

### AN ORDINANCE ANNEXING CERTAIN REAL ESTATE TO THE CITY OF WESTFIELD, HAMILTON COUNTY, INDIANA

**WHEREAS**, the Westfield City Council (the “Council”) has the authority and desires to annex lands into the municipality as defined by Indiana Code 36-4-3; and,

**WHEREAS**, one hundred percent (100%) of the owners of the parcels proposed for annexation as identified in **Exhibit A** and **Exhibit B** (the “Annexation Area”) have filed a petition with the Council; and,

**WHEREAS**, the Council has conducted a public hearing on February 9, 2026 as required by law with regard to the annexation of the Annexation Area; and,

**WHEREAS**, the Council has adopted a fiscal plan for the annexation of the Annexation Area in accordance with Indiana Code 36-4-3-3.1 (Resolution 26-102); and,

**WHEREAS**, the Annexation Area meets the contiguity requirements of Indiana Code 36-4-3-1.5; and,

**WHEREAS**, the Council now finds that the statutory criteria for annexation have been met; and,

**NOW THEREFORE BE IT ORDAINED BY THE WESTFIELD CITY COUNCIL THAT THE OFFICIAL CITY MAP ADOPTED BY REFERENCE IN SECTION 2-515 OF THE WESTFIELD CODE BE MODIFIED AS FOLLOWS:**

**Section 1.** The Annexation Area, generally located on the south side of E. 191<sup>st</sup> Street, and adjacent to the existing corporate limits along the north side of the parcel, is hereby annexed to and declared to be a part of the City.

**Section 2.** The Annexation Area is to further include the contiguous public highways and rights-of-way of the public highways which are adjacent to the annexation area per Indiana Code 36-4-3-2.5.

**Section 3.** The Annexation Area is hereby assigned to City Council District 3 and shall become a part thereof immediately upon the effective date of this Ordinance.

**Section 4.** This Ordinance shall be in full force and effect upon its passage by the Council, its publication, and upon the passage of any applicable waiting period, all as provided by the laws of the State of Indiana. All ordinances or parts thereof in conflict herewith are hereby repealed. Any portion of the Ordinance later to be found void or invalid shall not affect the remaining portions of this Ordinance.

ALL OF WHICH IS HEREBY ADOPTED BY THE CITY COUNCIL OF WESTFIELD,  
HAMILTON COUNTY, INDIANA THIS \_\_\_\_\_ DAY OF FEBRUARY, 2026.

WESTFIELD CITY COUNCIL  
HAMILTON COUNTY, INDIANA

**Voting For**

**Voting Against**

**Abstain**

\_\_\_\_\_  
Jon Dartt

\_\_\_\_\_  
Jon Dartt

\_\_\_\_\_  
Jon Dartt

\_\_\_\_\_  
Victor McCarty

\_\_\_\_\_  
Victor McCarty

\_\_\_\_\_  
Victor McCarty

\_\_\_\_\_  
Joe Duepner

\_\_\_\_\_  
Joe Duepner

\_\_\_\_\_  
Joe Duepner

\_\_\_\_\_  
Patrick Tamm

\_\_\_\_\_  
Patrick Tamm

\_\_\_\_\_  
Patrick Tamm

\_\_\_\_\_  
Noah Herron

\_\_\_\_\_  
Noah Herron

\_\_\_\_\_  
Noah Herron

\_\_\_\_\_  
Kurt Wanninger

\_\_\_\_\_  
Kurt Wanninger

\_\_\_\_\_  
Kurt Wanninger

\_\_\_\_\_  
Chad Huff

\_\_\_\_\_  
Chad Huff

\_\_\_\_\_  
Chad Huff

ATTEST:

\_\_\_\_\_  
Marla Ailor, Clerk Treasurer

I hereby certify that **ORDINANCE 26-05** was delivered to the Mayor of Westfield  
on the \_\_\_\_\_ day of February, 2026, at \_\_\_\_\_ m.

\_\_\_\_\_  
Marla Ailor, Clerk-Treasurer

I hereby APPROVE Ordinance 26-05  
this \_\_\_\_\_ day of February, 2026.

I hereby VETO Ordinance 26-05  
this \_\_\_\_\_ day of February,  
2026.

\_\_\_\_\_  
Scott A. Willis, Mayor

\_\_\_\_\_  
Scott A. Willis, Mayor

I affirm, under the penalties for perjury, that I have taken reasonable care to redact each Social Security number in this document,  
unless required by law: Ryan Collingwood



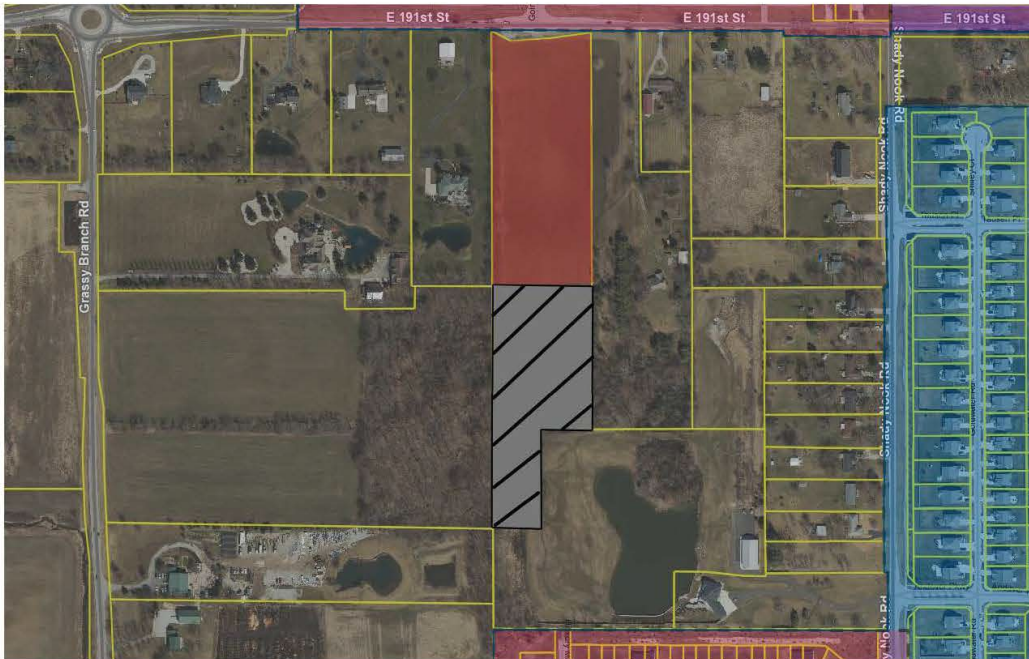

Prepared by: Ryan Collingwood, Senior Associate Planner  
City of Westfield Community Development Department  
2728 East 171<sup>st</sup> Street, Westfield, IN 46074, (317) 804-3170

# EXHIBIT A

## Annexation Area



### EXHIBIT LEGEND

- |   |                      |   |         |
|---|----------------------|---|---------|
|  | ANNEXATION AREA      |  | PARCELS |
|  | EXISTING CITY LIMITS |  | STREETS |

Not To Scale

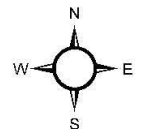

**EXHIBIT B**  
**ANNEXATION AREA**  
**LEGAL DESCRIPTION**

This description includes a portion of one (1) parcel of land:



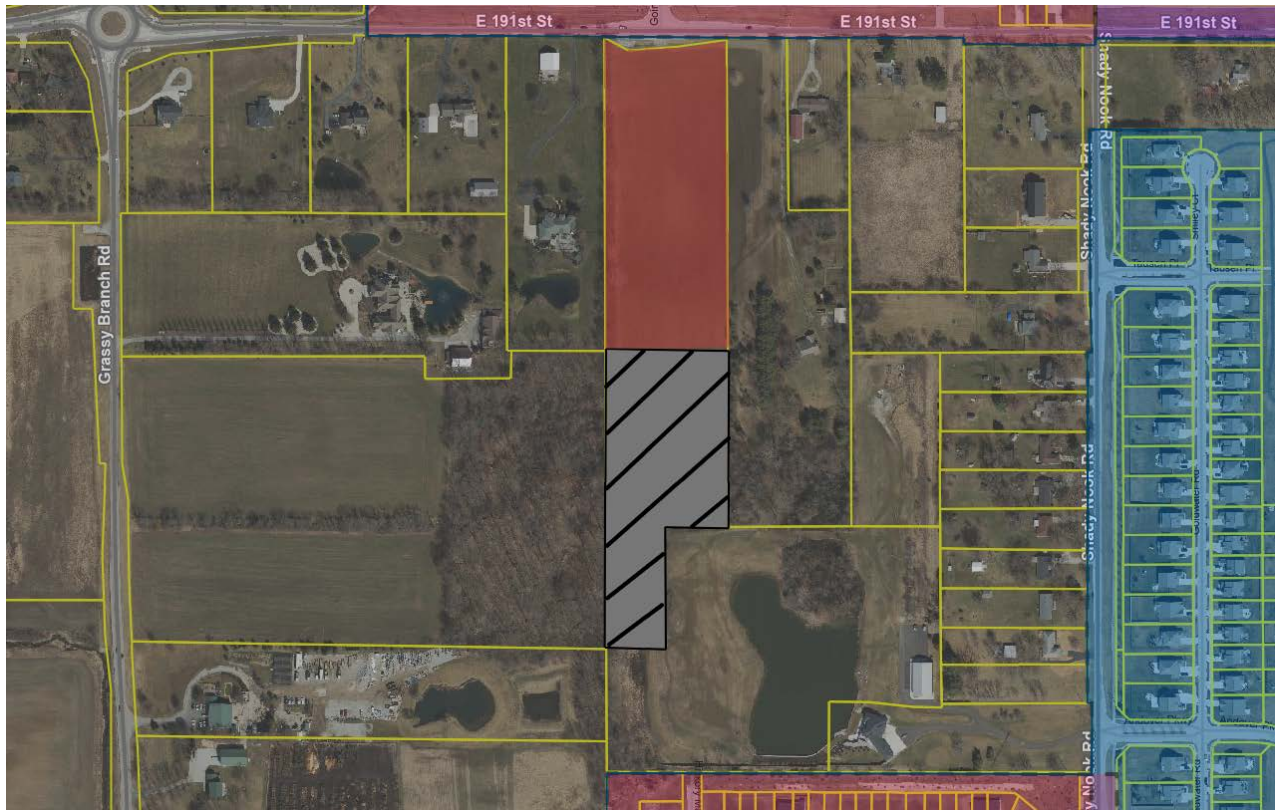

That portion of the West Half of the Southwest Quarter of Section 13, Township 19 North, Range 3 East, of the Second Principal Meridian, in Hamilton County, Indiana, and based on a survey prepared by Brian L. Haggard, LS29800001, certified on December \_\_, 2025, under V3 Companies Project No. 251346, described as follows:

Commencing at the northwest corner of said Southwest Quarter; thence South 00 degrees 00 minutes 00 seconds East (bearing per record deed) along the west line thereof 770.44 feet to the northwest corner of the land of Burns as described in Instrument Number 2019029392 in the Office of the Recorder of said county; thence South 89 degrees 30 minutes 42 seconds East along the north line thereof 624.32 feet to the POINT OF BEGINNING, said point being marked by a 5/8 inch rebar with cap stamped "V3 PX IN FIRM 0092" cap; thence continue South 89 degrees 30 minutes 42 seconds East along said north line 699.32 feet to the east line of said West Half, said point being South 00 degrees 05 minutes 29 seconds West 826.21 feet from the northeast corner of said West Half and is marked by a ½ inch rebar found 0.23 feet north and 0.45 feet west of the corner; thence South 00 degrees 05 minutes 29 seconds West along said east line 433.81 feet to the common west corner between Lot K65 and Common Area 7 in the plat of Chatham Hills, Section 3 recorded as Instrument Number 2017009750 in said county records, said point being marked by a 5/8 inch rebar with cap stamped "Structurepoint – 0094" cap; thence North 89 degrees 54 minutes 42 seconds West 698.60 feet to a 5/8 inch rebar with cap stamped "V3 PX IN FIRM 0092" cap; thence North 00 degrees 00 minutes 00 seconds East parallel with said west line 438.69 feet to the POINT OF BEGINNING, containing 7.000 acres, more or less.

# Annexation Area



## EXHIBIT LEGEND

- |   |                      |   |         |
|---|----------------------|---|---------|
|  | ANNEXATION AREA      |  | PARCELS |
|  | EXISTING CITY LIMITS |  | STREETS |

Not To Scale

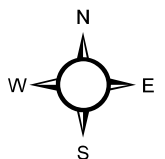

## ORDINANCE 26-07

### AN ORDINANCE TO AMEND PROVISIONS IN THE WESTFIELD-WASHINGTON TOWNSHIP UNIFIED DEVELOPMENT ORDINANCE

**WHEREAS**, the City of Westfield, (the “City”) is a duly formed municipal corporation within the State of Indiana, governed by its duly elected Mayor and Common Council (the “Council”); and,

**WHEREAS**, it is the duty and the responsibility of the City to administer the Westfield-Washington Township Unified Development Ordinance (the “UDO”) throughout the City and Washington Township, Indiana as identified through the adoption of a Joinder Agreement; and,

**WHEREAS**, from time to time it is necessary to amend and revise the UDO, and pursuant to I.C. § 36-7-4-602 and I.C. § 36-7-4-701, the City is authorized to amend the UDO; and

**WHEREAS**, on [REDACTED], 2026, the Westfield-Washington Township Advisory Plan Commission forwarded Petition No. 2603-ZOA-02 to the Council with a [REDACTED] recommendation in accordance with Indiana Code § 36-7-4-607; and

**NOW, THEREFORE, BE IT ORDAINED** by the Common Council of the City of Westfield, Hamilton County, Indiana, meeting in regular session, that the following provisions of the Unified Development Ordinance are amended as follows:

**Section 1.**     **Article 8.9(I) Street and Right-of-way Standards, Fire Hydrants** shall be amended as follows: Except for Minor Subdivisions in Agricultural Districts, ~~The~~ Developer shall provide the development with fire hydrants. The types of hydrants and location of hydrants shall be determined by the Fire Department.

**Section 2.**     **Article 8.13(B) Utility Standards, Sewer and Water** shall be amended as follows: Public Sanitary Sewer and ~~water~~ Public Water hook-up shall be required for development in all Zoning Districts, except for Minor Subdivisions in Agricultural Districts. In instances where Public Water is not available for hook-up, the Developer shall install signage in accordance with the Long Lay program, as determined by the Fire Department.

**Section 3.** Article 12.1 Definitions shall be amended as follows:

A. Add new definition to read as follows:

1. **Public Water:** Any water system provided and maintained by a county, municipality, or utility company involved in a water utility, including land, water sources, collection systems, dams and hydraulic structures, distribution systems, and other apparatus, pumping stations, treatment works, and general properties, or any parts thereof.

**Section 4.** This Ordinance shall be in full force and effect in accordance with Indiana law, upon the passage of any applicable waiting periods, all as provided by the laws of the State of Indiana. All ordinances or parts thereof that are in conflict herewith are hereby ordered repealed. All acts undertaken to in creation of this Ordinance are hereby ratified.

**[The remainder of this page intentionally left blank.]**

ALL OF WHICH IS ORDAINED THIS \_\_\_\_\_ DAY OF \_\_\_\_\_, 2026.  
WESTFIELD CITY COUNCIL

**Voting For**

**Voting Against**

**Abstain**

\_\_\_\_\_  
Jon Dartt

\_\_\_\_\_  
Jon Dartt

\_\_\_\_\_  
Jon Dartt

\_\_\_\_\_  
Victor McCarty

\_\_\_\_\_  
Victor McCarty

\_\_\_\_\_  
Victor McCarty

\_\_\_\_\_  
Joe Duepner

\_\_\_\_\_  
Joe Duepner

\_\_\_\_\_  
Joe Duepner

\_\_\_\_\_  
Patrick Tamm

\_\_\_\_\_  
Patrick Tamm

\_\_\_\_\_  
Patrick Tamm

\_\_\_\_\_  
Noah Herron

\_\_\_\_\_  
Noah Herron

\_\_\_\_\_  
Noah Herron

\_\_\_\_\_  
Kurt Wanninger

\_\_\_\_\_  
Kurt Wanninger

\_\_\_\_\_  
Kurt Wanninger

\_\_\_\_\_  
Chad Huff

\_\_\_\_\_  
Chad Huff

\_\_\_\_\_  
Chad Huff

ATTEST:

\_\_\_\_\_  
Marla Ailor, Clerk Treasurer

I hereby certify that **ORDINANCE 26-07** was delivered to the Mayor of Westfield  
on the \_\_\_\_\_ day of \_\_\_\_\_, 2026, at \_\_\_\_\_ m.

\_\_\_\_\_  
Marla Ailor, Clerk-Treasurer

I hereby APPROVE ORDINANCE 26-07  
this \_\_\_\_\_ day of \_\_\_\_\_, 2026.

I hereby VETO ORDINANCE 26-07  
this \_\_\_\_\_ day of \_\_\_\_\_, 2026.

\_\_\_\_\_  
Scott Willis, Mayor

\_\_\_\_\_  
Scott Willis, Mayor

This document prepared by:  
Ryan Collingwood  
Senior Associate Planner  
City of Westfield, Community Development Department  
2728 East 171<sup>st</sup> Street, Westfield, Indiana 46074 | (317) 804-3175

I affirm, under the penalties for perjury, that I have taken reasonable care to redact each Social Security Number in this document, unless required by law: Ryan Collingwood



## MEMORANDUM

January 28, 2026

**TO:** Westfield-Washington City Council Members; Advisory Plan Commission Members

**FROM:** Ryan Collingwood – Senior Associate Planner

**CC:** Westfield Community Development Staff

**SUBJECT:** UDO Patch – Minor Subdivisions & Water Applicability

**EXHIBITS:** 1. Memorandum  
2. Ord. 26-07

---

### *Overview & Background*

Please use this memo as a reference when reviewing proposed Ord. 26-07.

The subject UDO patch concerns itself with the application of water systems in regard to Minor Subdivisions within the AG-SF1: Agricultural / Single-family Rural Zoning District. Where public water systems may not be available, this patch would officially allow Minor Subdivisions in more-rural areas of the Township to utilize non-public water systems (well water) to gain access to water.

The patch essentially solidifies the procedure for water applicability in differing areas of the community.

---

### *Outline of Unified Development Ordinance (UDO) Amendments*

**a. UDO Article 8.9(I): Street and Right of Way Standards, Fire Hydrants**

- a. Current Verbiage: The Developer shall provide the development with fire hydrants. The types of hydrants and location of hydrants shall be determined by the Fire Department.
- b. Amended Verbiage: Except for Minor Subdivisions in Agricultural Districts, the Developer shall provide the development with fire hydrants. The types of hydrants and location of hydrants shall be determined by the Fire Department.

**b. UDO Article 8.13(B): Utility Standards, Sewer and Water**

- a. Current Verbiage: Public Sanitary Sewer and water hook-up shall be required for development in all Zoning Districts, except the *AG-SF1: Agriculture / Single-family Rural District*.
- b. Amended Verbiage: Public Sanitary Sewer and Public Water hook-up shall be required for development in all Zoning Districts except for Minor Subdivisions in Agricultural Districts. In instances where Public Water is not available for hook-up, the Developer shall install signage in accordance with the Long Lay program, as determined by the Fire Department.

**c. UDO Article 12.1: Definitions**

- a. Added definition of “Public Water” to help specify different water systems:
  - i. **Public Water**: Any water system provided and maintained by a county, municipality, or utility company involved in a water utility, including land, water sources, collection systems, dams and hydraulic structures, distribution systems, and other apparatus, pumping stations, treatment works, and general properties, or any parts thereof.

---

*Plan Commission Action*

- a. Hold a public hearing at the March 2, 2026 Plan Commission meeting.
- b. Unless substantial concerns are raised at the Public Hearing, Staff requests the Commission vote to waive the scheduled workshop and immediately vote on the recommendation to Council.

---

Please do not hesitate to contact me with any questions, comments, or concerns. Thank you!



Ryan Collingwood – Senior Associate Planner  
[rcollingwood@westfield.in.gov](mailto:rcollingwood@westfield.in.gov)